

EXPERIMENTS USING ELECTRICITY TO PREVENT FOULING IN MEMBRANE FILTRATION

R.J. Wakeman and E.S. Tarleton (e.s.tarleton@lboro.ac.uk)
Separation Processes Centre, University of Exeter, Exeter, UK.

ABSTRACT

Experimental data obtained from a tubular crossflow filter are presented. The effects of operating conditions, including feed concentration, crossflow and throughflow velocities, and imposed electric fields are discussed with reference to the data. A method of reducing the consumption of electrical power based on some further results is noted. Permeate flux can be considerably enhanced using a d.c. electric field, and this is attributed to reduced particulate fouling of the membrane.

INTRODUCTION

Separation of fine particles and colloids from relatively dilute suspensions is a common requirement in the traditional production of commodity chemicals, the lower tonnage but highly specific manufacture of pharmaceuticals, and a range of fermentation processes. Ultrafiltration systems utilise a high velocity transverse flow over a polymeric membrane to prevent contaminant deposition; the pores in the asymmetric membranes have sizes of the order of 0.02 micron or smaller. The use of larger pore size media with crossflow is known as microfiltration to distinguish it from other membrane methods. Microfiltration units are widely used for the clarification and sterilisation of liquids, and although capable of removing particles down to about 0.1 micron, microfiltration is suitable for low concentration feed streams only.

Crossflow microfiltration involves the motion of a suspension tangential to the surface of a filter medium or membrane; the geometric form of the filter is either that of a 'plate and frame type filter', or 'tubular' with the filter being a porous tube mounted centrally inside a solid tube and the feed pumped into the annular space between the two. In most cases a microfilter is required to retain all particles larger than a specified size, whilst the suspending fluid and low molecular weight components pass through the filter medium.

Whilst the bulk flow is tangential to the medium or membrane there is also a convective flow into the porous wall which causes particles to be transported laterally towards the membrane. The particle concentration near the membrane surface can increase significantly and even result in the deposition of particles as either a fouling layer or a cake on the surface; the so-called 'particle polarisation' effect. This reduces the filtrate or permeate flux through a simple crossflow filter, and the effect is widely recognised as a cause of the performance loss in microfiltration and ultrafiltration operations.

This communication presents some data from an experimental investigation into the use of d.c. electric fields to prevent particle deposition, with the objective of maintaining high permeate or filtrate fluxes.

EXPERIMENTAL APPARATUS

The experimental equipment is shown schematically in Figure 1. Suspension, made up to a known solids concentration in prefiltered water, was pumped into the annular section between the tubular filter and its housing; clean permeate was collected from the central core of the filter at a measured flow rate, and the remaining crossflowing suspension returned via a rotameter to a 225 litre feed reservoir. The vertical filter unit was designed to hold 25, 50 or 75 cm cartridges, which were generally of the pleated polypropylene type with pore sizes of 0.2 or 1 micron. A regulated power

Cite paper as: Wakeman R.J. and Tarleton E.S., 1986, Experiments using electricity to prevent fouling in membrane filtration, *Filtration and Separation*, **23**(3), 174-176. Also presented at Membranes in Filtration Systems Conference, 1986, The Filtration Society, Manchester, UK.

supply with a maximum output of 400 V d.c. at 10 A was used to provide a constant potential difference across the flow cross-section of the filter, indicated in Figure 2. Filtrations were carried out for between 45 and 120 minute run times, with permeate flux depletion monitored for the duration of each experiment.

Each suspension was characterised by measuring the particle, or strictly agglomerate, size distribution and the zeta potential at various pH levels. From these a rapid assessment of the likely success of the particle deposition prevention process could be made; deposition of particles with sizes in a distribution of predominantly 4 microns or larger or with a zeta potential smaller than about 20 mV is unlikely to be prevented. For each suspension this has been checked in a deadend filter as used previously.

RESULTS

The following experimental results show the trends obtained by varying the electric field, feed concentration, and initial permeate rate (that is, the pressure difference across the membrane) in a systematic manner.

Figure 3 shows typical effect of increasing the electric field on the permeate flow rate. Under the conditions of the experiments quoted, the permeate rate falls to about 20% of its initial value with 30 minutes of operation when no field is imposed. Imposing an electric field of 98 V/cm causes fewer particles to deposit and the rate falls to just under 50% of its initial value in 30 minutes. These results confirmed the expectations from earlier studies¹ in a deadend filter cell and demonstrate that an electric field can facilitate higher permeate fluxes in crossflow filters. Similar results are available for other particulates over a wide range of experimental conditions².

Further results are shown in Figure 4 for a higher initial permeate rate. At first sight the data in Figures 3 and 4 appear somewhat contradictory in so far as a higher permeate rate might be expected to lead to a greater deposit on the membrane and hence to a more rapid reduction of the permeate rate. Actually, the results are consistent with those obtainable from conventional filtration processes. The higher initial permeate rate does cause greater deposition, but the number of particles deposited per unit time is such that a bridging filtration mechanism predominates in Figure 4, whereas a blocking mechanism dominates deposition in Figure 3. Hence, although a greater deposit has been formed in the experiments shown in Figure 4 its permeability is greater and so a higher permeate flux is sustained, whilst the combined surface shear and electrophoretic forces limit growth of the deposit. This highlights the controlling role played by the deposit at the start of the separation (and even suggests that for a few exceptional applications membrane pre-coating would offer considerable advantages). The progressive improvement in permeate flux as the potential gradient is increased is self-evident in Figure 4, but an interesting feature has apparently started to emerge at 98 V/cm.

After a while the permeate flux starts to rise, presumably because the hydrodynamic drag force holding the particles at the deposit surface has fallen to such a level due to the permeate flux reduction that it has become smaller than the combined shear and electrophoretic forces. These latter forces are then causing particles to be re-entrained into the suspension, resulting in a rise of the permeate flux. If this reasoning is correct then a cyclic behaviour of permeate flux with time will result, cycling between fluxes equivalent to two equilibrium force levels as the hydrodynamic drag falls and rises due to respective increases and decreases in the amount of deposit on the membrane. Under some conditions the amplitude of the cycling will be small and in other cases such an observation will not be discernable, particularly if too low an electrophoretic force is applied. The improvements in fluxes at 1000 s shown in Figures 3 and 4 are given in Table 1, which emphasises the improvements attainable – at the lower initial permeate rate an 84% improvement in flux is obtained.

Typical experimental effects of slurry concentration are indicated in Figures 5 and 6. With greater feed concentrations, deposition is more rapid, but at all concentrations below about 1% v/v improvements in the permeate flux were noted when an electric field was employed. The improvements shown by these figures are listed in Table 2.

At higher feed concentrations deposition is very rapid (Figure 7) and the effect of the electric field is to remove particles from the deposit and create the possibility of a cycling permeate flux. The precise flux measurements obtained are dependent on feed concentration and pressure difference over the membrane, and it should be noted that lesser effects than shown in Figure 7 can be obtained at lower feed concentrations if the initial permeate rate is too high; the effect can be to nullify any potential advantage of the electric field and to create a situation where repeated backwashing (or other form of membrane cleaning) becomes obligatory.

Data for another system, rutile, is shown in Figure 8. The most interesting feature here is the use of the electric field to remove an initial deposit from the membrane and thereafter operate at a flux very close to the initial value; it is possible that this is again part of a flux cycling pattern between two equilibrium force levels. Continuous thickening of a suspension is being achieved at an almost constant rate, and close to a maximum rate, which may be pertinent to applications of slurry thickening prior to filtration to improve the characteristics of the latter.

Having verified the flow rate advantages to be gained when using an electric field, it is pertinent to consider ways to reduce the electrical power consumption whilst retaining the benefits. A number of experiments have been carried out in which the potential has been pulsed; the separation is started with the field switched on, after a time lapse it is switched off, and this switching pattern is repeated throughout the experiment using the same time lapse between switching the power on or off. Some results are shown in Figures 9 and 10. In Figure 9 the data for the 120 s pulse durations is showing that an almost constant (RMS) rate separation is being achieved, and that rate is rather better than that obtained when using a constant field.

Similar remarks apply to the data in Figure 10. However, the 300 s data in Figure 9 and both pulsed experiments in Figure 10 possibly point to a further interesting phenomenon. When the power was turned on for the second and subsequent times a surge in the flux is observed which then diminishes until the power is again turned on. It is difficult to imagine how such a surge might be attributed to electrophoresis; it is possible, however, that a sudden electroosmotic flow is created, and this may be combined with a modification to the viscosity of the fluid by the field. These effects clearly require further investigation before the role of the concepts in fouling prevention can be elucidated.

CONCLUSIONS

- The contribution of fine particles and colloids to membrane fouling can be reduced by application of a d.c. electric field across the membrane
- Enhancements of permeate flux tend to be greater when the feed concentration is lower and the pressure difference across the membrane is smaller
- Electrophoretic effects can account for much of the particle removal from the membrane surface, but may well be accompanied by electroosmotic and viscosity modifying phenomena
- Greater permeate flux improvements can sometimes be obtained at the expense of less electrical power consumption by pulsing the potential.

ACKNOWLEDGEMENT

Cite paper as: Wakeman R.J. and Tarleton E.S., 1986, Experiments using electricity to prevent fouling in membrane filtration, *Filtration and Separation*, **23**(3), 174-176. Also presented at Membranes in Filtration Systems Conference, 1986, The Filtration Society, Manchester, UK.

This work was carried out as part of a specially promoted programme in particulate technology sponsored by the Science and Engineering Research Council, to whom the authors wish to express their gratitude for receipt of a research grant.

REFERENCES

1. Wakeman R.J., *Filtration and Separation*, **19**, 316, 1982.
2. Tarleton E.S., *Ph.D. Thesis*, University of Exeter, 1986.
3. Wakeman R.J. and Tarleton E.S., *Proc. 4th World Filtration Congress*, pp.11.1-11.10, Technologisch Instituut-Koninklijke Vlaamse Ingenieursvereniging, Ostend, Belgium.

FIGURES AND TABLES

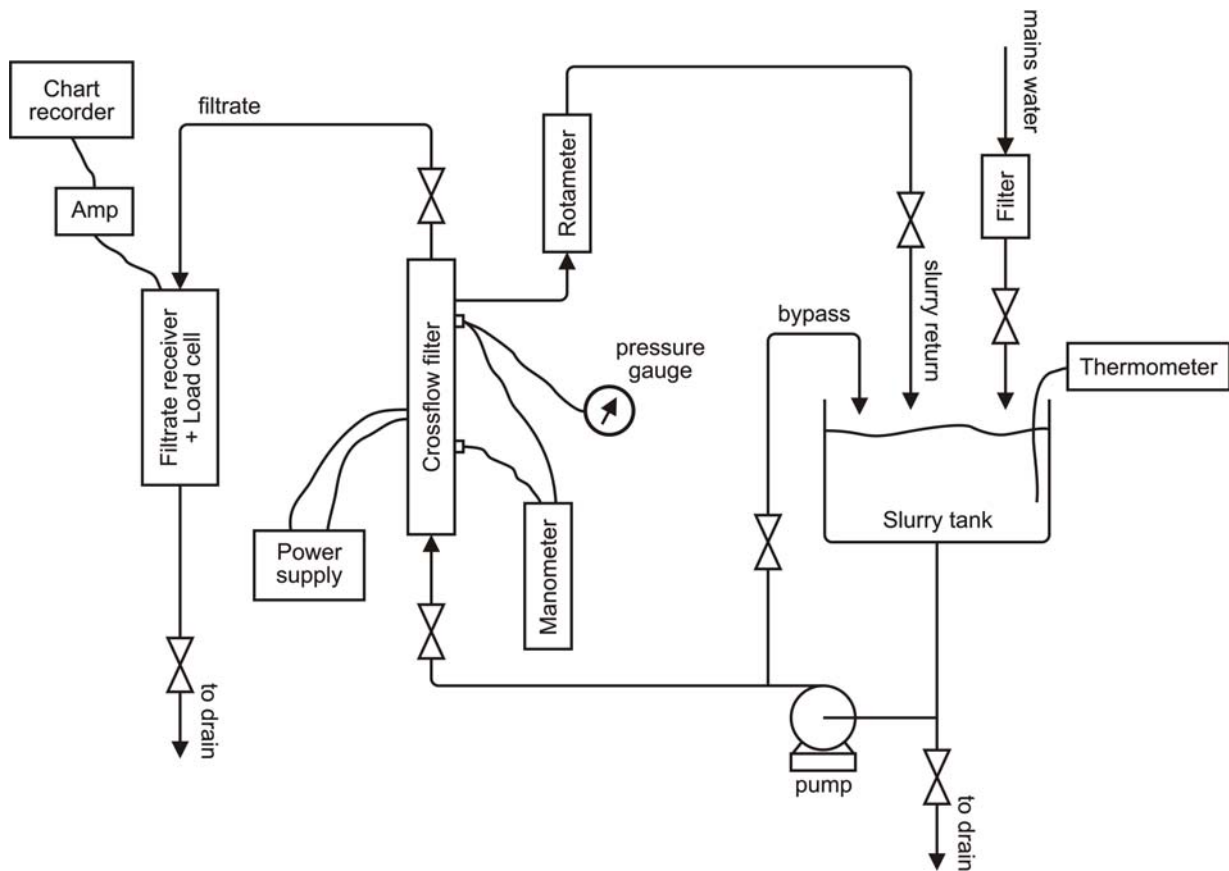

Figure 1: Schematic diagram of experimental crossflow filter apparatus.

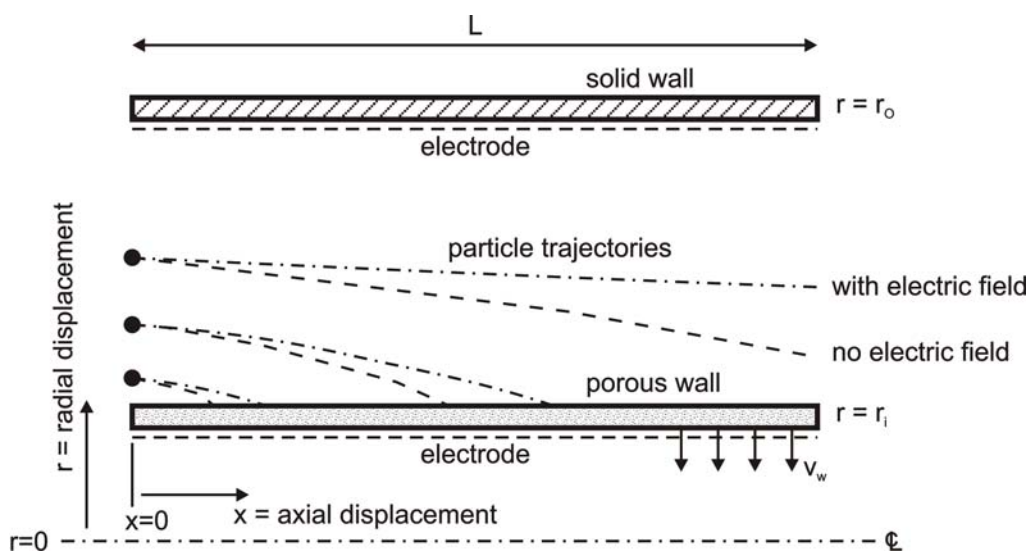

Figure 2: Particle and liquid flows through an annulus with a porous inner wall.

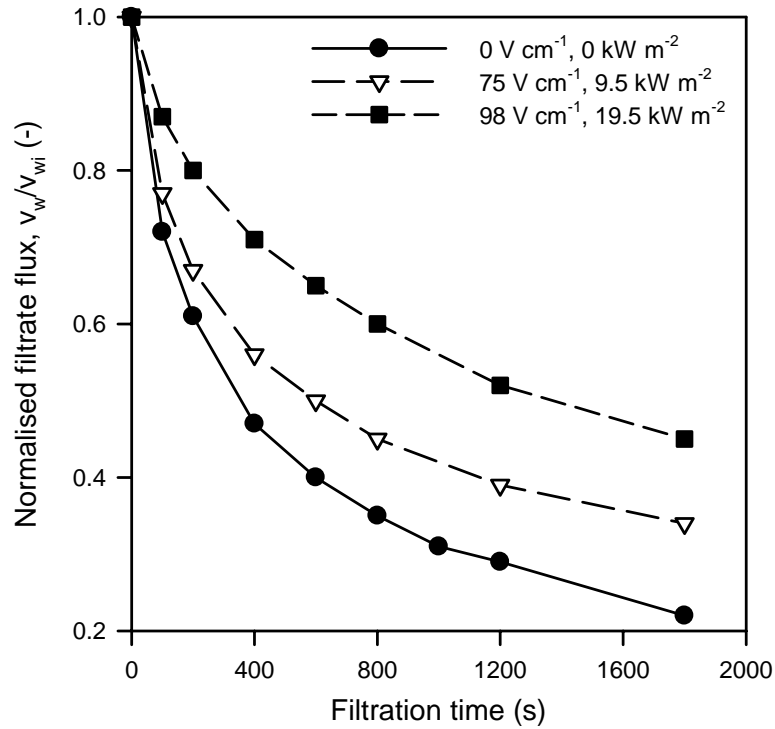

Figure 3: Effect of electric field upon filtration of china clay. Feed concentration = 0.04% by volume; crossflow velocity = 0.9 m s^{-1} ; initial filtration flux = $2.18 \text{ m}^3 \text{ m}^{-2} \text{ h}^{-1}$.

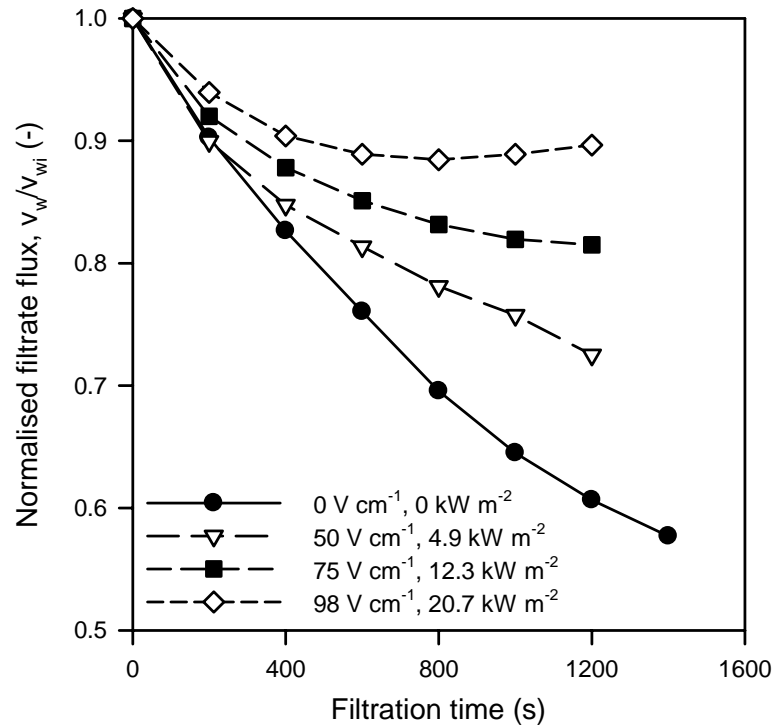

Figure 4: Effect of electric field upon filtration of china clay. Feed concentration = 0.04% by volume; crossflow velocity = 0.9 m s^{-1} ; initial filtration flux = $4.14 \text{ m}^3 \text{ m}^{-2} \text{ h}^{-1}$.

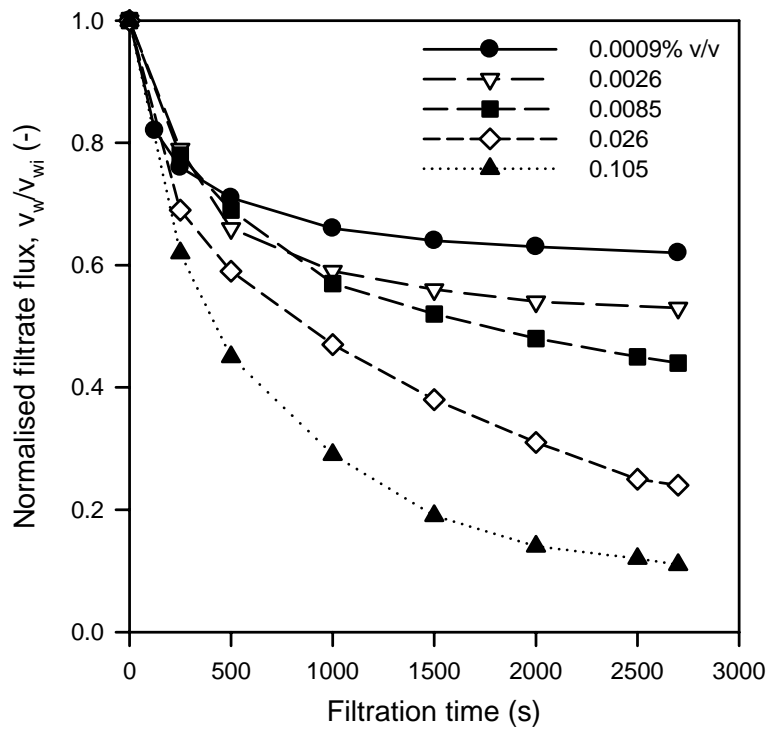

Figure 5: Effect of slurry concentration upon filtration of anatase ($E = 0 \text{ V cm}^{-1}$). Crossflow velocity = 0.9 m s^{-1} .

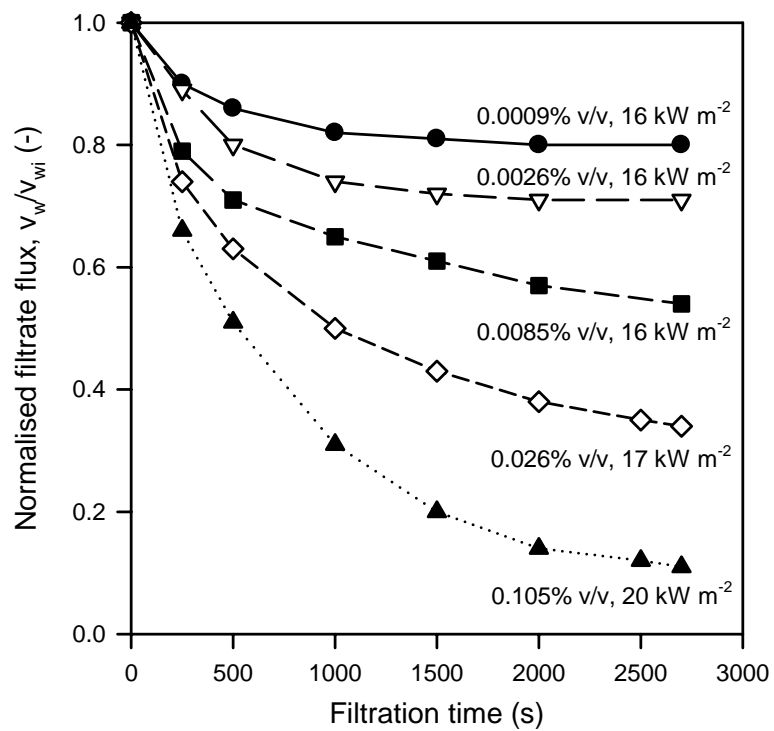

Figure 6: Effect of slurry concentration upon filtration of anatase ($E = 98 \text{ V cm}^{-1}$). Crossflow velocity = 0.9 m s^{-1} .

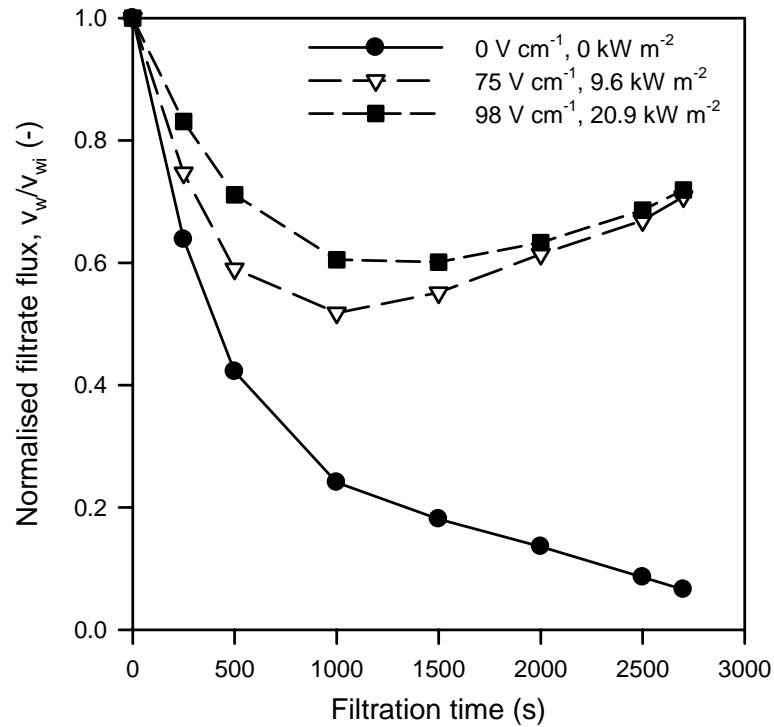

Figure 7: Effect of electric field upon filtration of china clay. Feed concentration = 1% by volume; crossflow velocity = 0.9 m s^{-1} ; initial filtration flux = $0.48 \text{ m}^3 \text{ m}^{-2} \text{ h}^{-1}$.

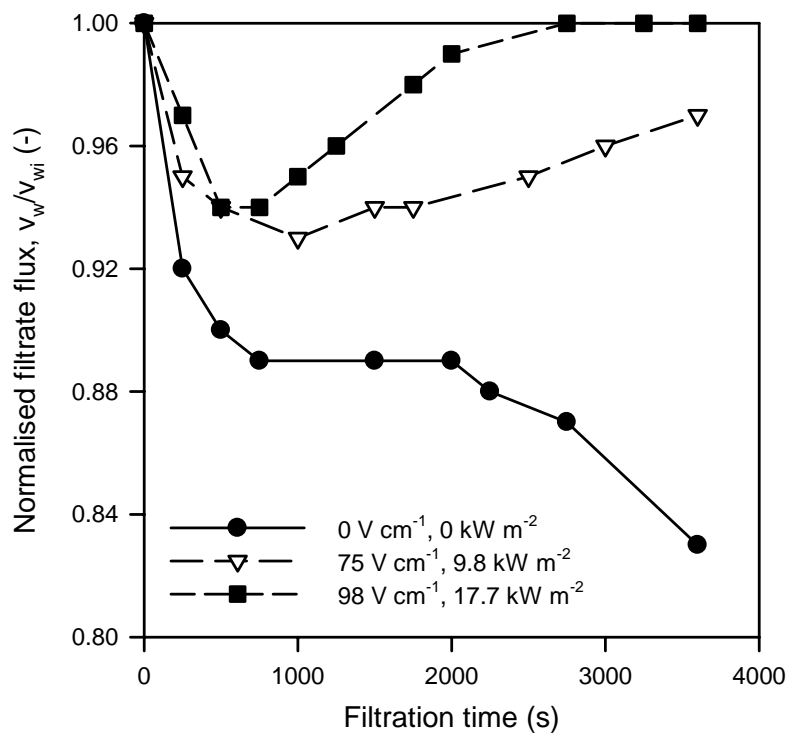

Figure 8: Effect of electric field upon filtration of rutile. Feed concentration = 0.008% by volume; crossflow velocity = 0.9 m s^{-1} ; initial filtration flux = $0.91 \text{ m}^3 \text{ m}^{-2} \text{ h}^{-1}$.

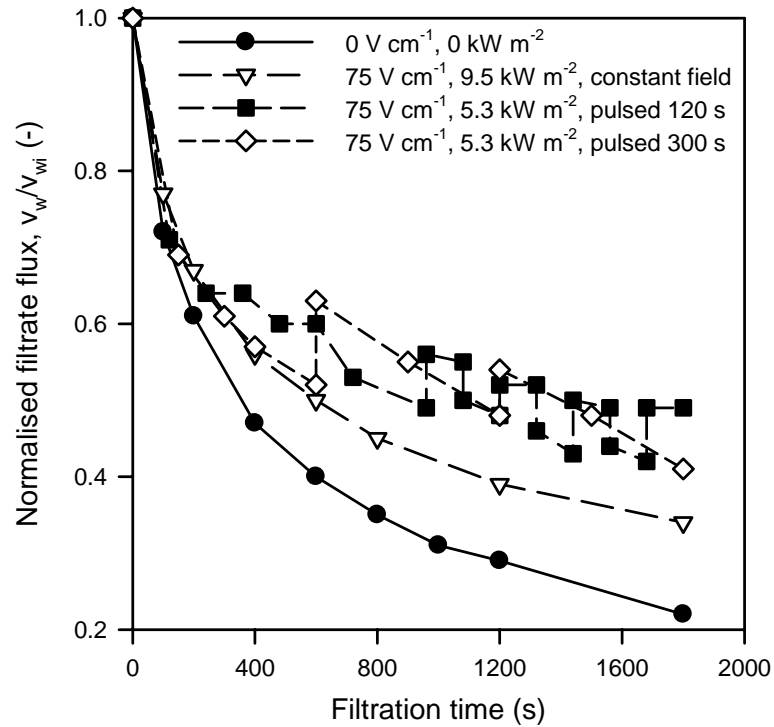

Figure 9: Effect of pulsed electric field upon filtration of china clay. Feed concentration = 0.04% by volume; crossflow velocity = 0.9 m s^{-1} ; initial filtration flux = $2.18 \text{ m}^3 \text{ m}^{-2} \text{ h}^{-1}$.

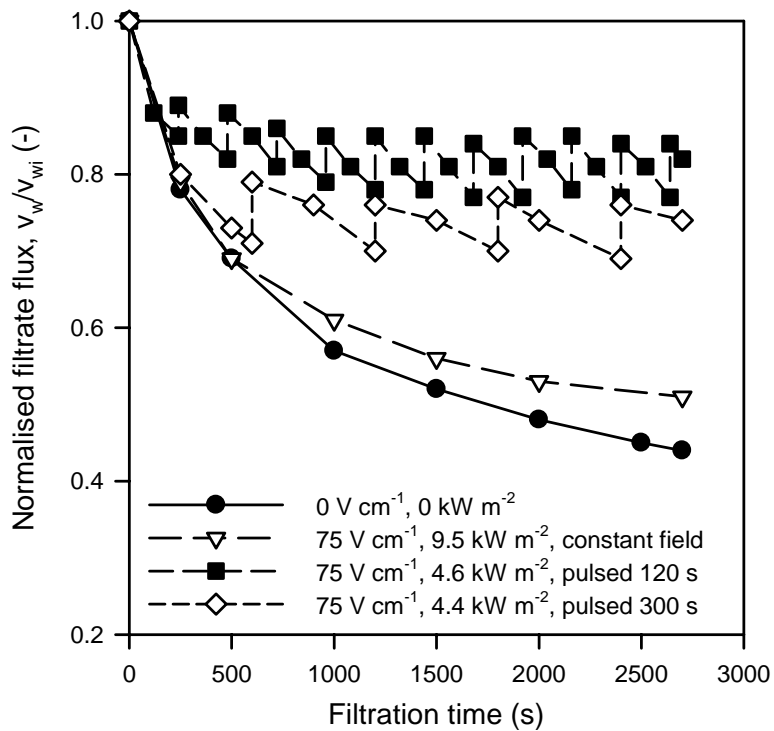

Figure 10: Effect of pulsed electric field upon filtration of anatase. Feed concentration = 0.009% by volume; crossflow velocity = 0.9 m s^{-1} ; initial filtration flux = $2.1 \text{ m}^3 \text{ m}^{-2} \text{ h}^{-1}$.

Initial flux ($\text{m}^3 \text{m}^{-2} \text{h}^{-1}$)	Permeate flux after 1000 s as fraction of initial flux		% improvement in flux	Power consumption (kW m^{-2})
	$E = 0 \text{ V/cm}$	$E = 98 \text{ V/cm}$		
2.18	0.31	0.57	84	20
4.14	0.65	0.89	27	21

Table 1: Some permeate flux comparisons for china clay.

% v/v solids in feed	Permeate flux after 1000 s as fraction of initial flux		% improvement in flux	Power consumption (kW m^{-2})
	$E = 0 \text{ V/cm}$	$E = 98 \text{ V/cm}$		
0.0009	0.67	0.84	25	16
0.0026	0.6	0.74	23	16
0.009	0.57	0.65	14	16
0.026	0.46	0.51	10	17
0.105	0.29	0.32	10	20

Table 2: Some permeate flux comparisons for anatase.