

Loughborough University  
Institutional Repository

---

*The removal of solutes from  
organic solvents using  
nanofiltration*

This item was submitted to Loughborough University's Institutional Repository by the/an author.

**Citation:** ROBINSON, J.P. and TARLETON, E.S., 2004. The removal of solutes from organic solvents using nanofiltration. Proc. Innovations in Filtration and Separation Conference, Paper 7, The Filtration Society, Loughborough.

**Additional Information:**

- This is a conference paper. It is also available at: [www.filtsoc.com](http://www.filtsoc.com)

**Metadata Record:** <https://dspace.lboro.ac.uk/2134/5120>

**Version:** Accepted for publication

**Publisher:** © Filtration Society

Please cite the published version.

This item was submitted to Loughborough's Institutional Repository (<https://dspace.lboro.ac.uk/>) by the author and is made available under the following Creative Commons Licence conditions.

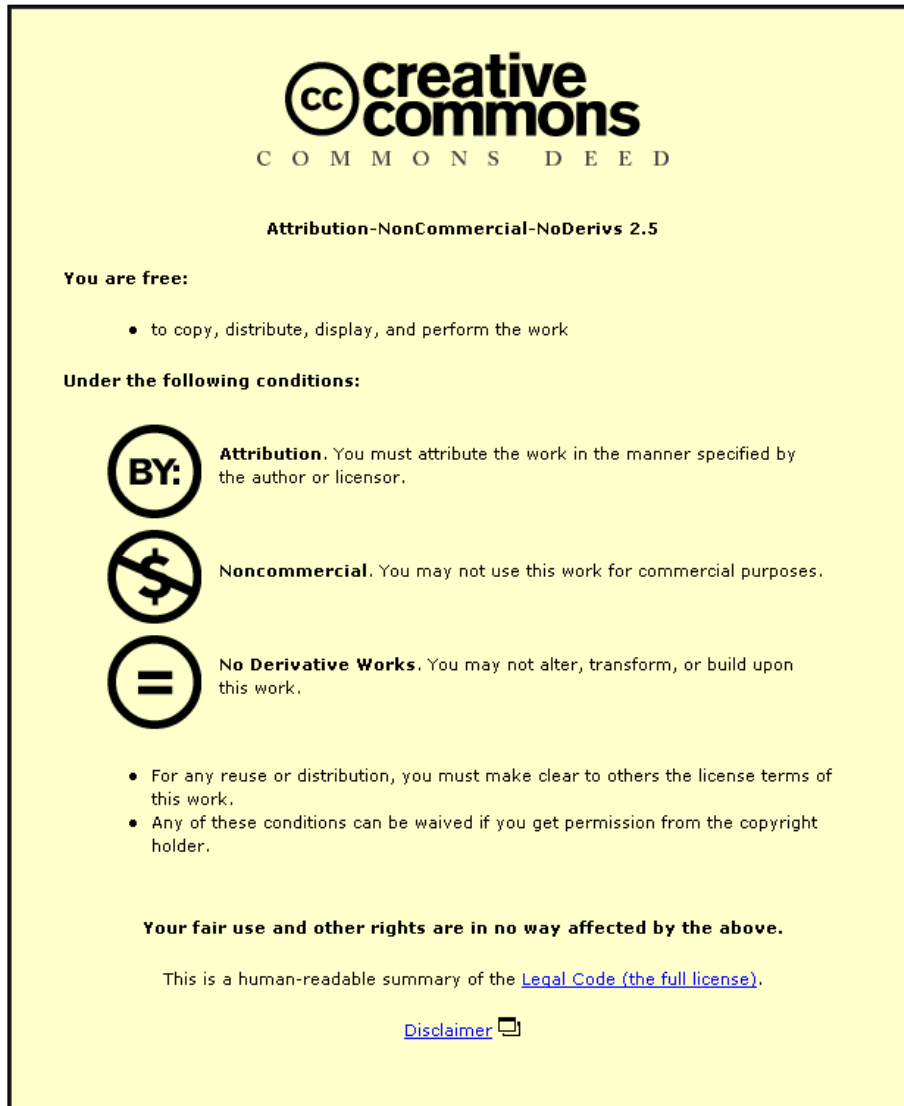

CC creative commons  
COMMONS DEED

**Attribution-NonCommercial-NoDerivs 2.5**

**You are free:**

- to copy, distribute, display, and perform the work

**Under the following conditions:**

 **Attribution.** You must attribute the work in the manner specified by the author or licensor.

 **Noncommercial.** You may not use this work for commercial purposes.

 **No Derivative Works.** You may not alter, transform, or build upon this work.

- For any reuse or distribution, you must make clear to others the license terms of this work.
- Any of these conditions can be waived if you get permission from the copyright holder.

**Your fair use and other rights are in no way affected by the above.**

This is a human-readable summary of the [Legal Code \(the full license\)](#).

[Disclaimer](#) 

For the full text of this licence, please go to:  
<http://creativecommons.org/licenses/by-nc-nd/2.5/>

## THE REMOVAL OF SOLUTES FROM ORGANIC SOLVENTS USING NANOFILTRATION

J.P. Robinson and E.S. Tarleton ([e.s.tarleton@lboro.ac.uk](mailto:e.s.tarleton@lboro.ac.uk))

Advanced Separation Technologies Group, Department of Chemical Engineering, Loughborough University, Loughborough, Leicestershire, LE11 3TU, UK.

### ABSTRACT

Transport mechanisms and process limitations are relatively well understood for aqueous nanofiltration systems. Much work has also been done on the use of membranes for the removal of suspended matter from organic solvents. The removal of organic solute compounds from organic solvents using membrane technology has been addressed by very few workers, and little is known of the fundamental transport and separation mechanisms. A dense polydimethylsiloxane (PDMS) composite membrane was used to assess the flux and separation performance of a range of organic solute compounds and organic solvents. Solvent flux was modelled with the Hagen-Poiseuille equation and found to fit the model well, with swelling effects being the most likely cause of some deviations. The effect of solvent type and membrane swelling on solute rejection is discussed.

### KEYWORDS

Nanofiltration; Membrane; PDMS; Non-aqueous; Solute rejection; Swelling

### INTRODUCTION

Nanofiltration (NF) is a process largely associated with aqueous systems such as the purification of drinking water. In recent times the feasibility of using polymeric NF membranes for non-aqueous systems has been explored, examples include the recovery of organometallic catalysts from organic solvents<sup>1</sup> and the de-acidification of vegetable oils<sup>2</sup>. The initial development of thermodynamic theories was carried out by Paul and Ebra-Lima<sup>3</sup> as early as 1970 whilst studies into polymer-solvent interactions were documented by Flory<sup>4</sup> in the 1950s and since by others<sup>5,6</sup>. More recent work has attempted to enhance the understanding of both hydraulic (physical) and chemical transport mechanisms as well as solute rejection.

When hydraulic transport is the predominant mechanism, viscous liquid flow through a membrane (and other porous media) is pressure dependent and described by the Hagen-Poiseuille equation:

$$J = \left( \begin{matrix} \text{membrane} \\ \text{properties} \end{matrix} \right) \left( \begin{matrix} \text{system} \\ \text{parameters} \end{matrix} \right) = \left( \frac{\varepsilon r^2}{8L\tau} \right) \left( \frac{\Delta P}{\mu} \right) \quad (1)$$

where  $J$  is the flux,  $\varepsilon$  the porosity,  $r$  the average pore radius,  $\Delta P$  the differential pressure across the membrane,  $\mu$  the liquid viscosity,  $L$  the membrane thickness and  $\tau$  the tortuosity factor. Equation (1) can be sub-divided into membrane properties (porosity, membrane thickness etc.) and system parameters (pressure and viscosity). Under the viscous flow regime liquid mixtures will not undergo separation unless there are significant interactions between a particular component and the membrane. In the wider context, Zwijnenberg *et al.*<sup>2</sup> demonstrate the importance of surface energy for both polar and non-polar solvents with hydrophilic membranes. Permeation through membrane pores is shown to be possible only when the difference in surface energy can be overcome by the applied pressure. Bhanushali *et al.*<sup>7</sup> have also shown that solvent surface tension is inversely proportional to flux for hydrophobic membranes as the polarity of organic solvents is strongly related to surface tension.

With chemical transport, the solution-diffusion concept first proposed by Lonsdale *et al.*<sup>8</sup> is favoured. The passage of a substance occurs via a dissolution-diffusion mechanism such that the separation potential is determined by differences in solubility and diffusivity<sup>9</sup>; the sorption process generally being non-ideal<sup>10,11</sup>. An alternative approach is the pore-flow model, where even the densest membrane is modelled as a porous structure through which solvent transport takes place. The Hildebrand solubility parameter,  $\delta$ , is one method of estimating solvent affinity for a particular polymer membrane<sup>12</sup>. The parameter takes into account hydrogen-bonding, polar and dispersive effects, and can be assigned to both solvents and polymers from their molecular structures and chemical groups. Solvents and polymers that exhibit similar values of Hildebrand parameter are expected to interact strongly to give high solubility of the solvent in the polymer and hence significant polymer swelling. Such concepts have been assessed by Bhanushali *et al.*<sup>7</sup> who found that solvents with  $\delta \approx 15.5$  (MPa)<sup>0.5</sup> cause PDMS membranes, which have a similar value of  $\delta$ , to swell the most, with a maximum solubility of ~2 g solvent per g of polymer. The degree of swelling is dependent on the solvent type (i.e. the value of  $\delta$  of the solvent) and the amount of crosslinking present in the membrane material. A high degree of crosslinking results in a more rigid material and hence a lesser amount of swelling.

The rejection of organic solutes from organic solvents with polymer membranes has been addressed by relatively few workers. Scarpello *et al.*<sup>1</sup> studied organometallic solutes in a range of solvents with an MPF-50 membrane (similar to PDMS) and found that rejection increased with pressure, a phenomenon predicted by the solution-diffusion model. Gibbins *et al.*<sup>13</sup> have also reported an increase in rejection with pressure, and found that rejection increased with solute molecular weight. The results of Gibbins favour the pore-flow model, as their measured solute flux was 1000x that predicted by the solution-diffusion model. Yang *et al.*<sup>14</sup> in a study with aromatic dyes found rejection to vary according to the solvent used, and that the manufacturer specified molecular weight cut-off (MWCO) determined for the membrane with aqueous media is not valid for organic solvents. Increasing rejection with pressure and molecular weight, and solvent-specific rejections were also reported by van der Bruggen *et al.*<sup>15</sup> and Koops *et al.*<sup>16</sup>, the latter employed cellulose-acetate membranes rather than the silicon-based membranes studied by other workers.

In conclusion, whilst some workers have found rejection data to be in agreement with the solution-diffusion model, others studying similar systems have found the pore-flow model to be a better descriptor. It is possible that a transitional mechanism exists in non-aqueous NF systems. In the current study, a range of solutes in non-polar solvents have been used to investigate flow/rejection behaviour across PDMS to develop a further understanding of the prevalent transport mechanisms.

## EXPERIMENTAL PROPERTIES AND PROCEDURES

### Membrane

PDMS is a dense (non-porous) membrane with wide uses in the fields of gas separation, pervaporation and vapour permeation. PAN (polyacrylonitrile)/PDMS composite membranes with a nominal PDMS thickness of 2  $\mu\text{m}$  were used for the current study. When received, the  $\text{N}_2$  permeability was checked and found to be  $280 \pm 10$  barrer assuming the nominal 2  $\mu\text{m}$  thickness to be representative. An  $\text{O}_2/\text{N}_2$  selectivity of 2.2 has previously been reported for the membrane [17] and data related to  $\text{O}_2/\text{N}_2$  selectivity and pure nitrogen permeation verify that the selective layer in the membrane is PDMS rather than the PAN substrate material [18].

### Solvents and Solutes

Alkane and aromatic solvents: Organometallic and poly-nuclear aromatic (PNA) solutes, were chosen to be representative of those found in the industrial processes of interest. n-hexane, n-

heptane, cyclohexane and xylene were obtained from Sigma-Aldrich Ltd. Branched isomeric alkanes, i-hexane, i-heptane and i-octane were supplied by Shell Global Solutions. Model solute compounds were obtained from Sigma-Aldrich, Fisher Scientific and Strem Chemicals and selected on the basis of their solubility, molecular weight and abundance. A further criteria was the ease with which their concentration in a particular solvent could be determined using spectrometric techniques.

## Apparatus

Solvent flux was measured in a dead-end mode of operation, at pressures from 1 – 9 bar. Solute rejection experiments were performed in a cross-flow mode using the apparatus depicted in Figure 1.

The mixtures for study are added to a 2.5 litre capacity reservoir. An air-driven pump delivers the fluid to the membrane module via a variable area flow meter, a flow control valve and a 15  $\mu\text{m}$  pre-filter. The permeate can be recirculated to the reservoir, or collected as a separate stream. The retentate stream passes through a cooler, which uses the exhaust air from the pump to cool the circulating fluid, and is fed back into the reservoir. Trans-membrane pressure and solvent crossflow are controlled primarily by the back-pressure regulator and the air-regulator to the pump, the flow-control valve is used to make more sensitive adjustments. The membrane module used was a SEPA-CF membrane cell, available commercially from Osmonics, US. The module holds a flat-sheet membrane with a wetted surface area of 75  $\text{cm}^2$ .

The maximum pressure and crossflow obtainable with this configuration are limited by the viscosity of the solvent, although pressures of 8 bar and crossflow rates of 0.7 litres/min were regularly achievable.

## RESULTS AND DISCUSSION

The results summarise the data obtained for the range of solvents, solutes and operating conditions described. They are representative of the complete data set obtained.

### Flux and Rejection Measurements

Pure solvent flux ranged from 3 – 80  $\text{l m}^{-2} \text{h}^{-1}$  depending on the solvent used and the operating pressure. A comparison of the solvent flux behaviour with the Hagen-Poiseuille model described by Equation (1) is shown in Figure 2.

For the chosen solvents, the data fall on three distinct regression lines that correlate well with the different classifications of solvent. The divisions of gradient show that solvent groups affect their own membrane properties (i.e. values of  $\epsilon r^2 / (8L\tau)$ ) whilst individual items within a classification produce similar degrees of swelling. Although one of several parameters may be altered by the change in solvent, the (effective) pore radius,  $r$ , is most likely to experience the largest impact due to the solvent/polymer combination. When swollen, it seems that the structure of the dense PDMS layer changes to become porous, allowing viscous flow to a level partly dependent on the swelling properties of the solvent.

Further experiments (not reported here) show that two distinct regions in the flux-pressure relationship can exist for solvents. Possible reasons include the linear and reversible compaction of the PDMS layer at pressures up to  $\sim 2$  bar and/or a small, but finite, contribution to transport from chemical mechanisms [19].

When a mixture of alkane and aromatic solvents was permeated through a membrane sample, no separation was noted within the resolution of the refractometry detection technique. This again

points to a viscous flow regime and a porous membrane structure. If a chemical transport mechanism was significant then a separation of components would be expected due to differences in diffusion rates. Similar results have been reported by Machado *et al.*<sup>20</sup> for a range of solvent mixtures with silicon-based MPF-50 membranes.

The influence of swelling on flux was emphasised by experiments with water (a polar solvent). The viscosity of water is similar to that of cyclohexane and thus, for a constant membrane porosity/pore size and a simple hydraulic transport mechanism, the rate of water permeation should be close to that recorded with cyclohexane. Permeation tests with the PDMS membrane indicated zero water flux up to the maximum system pressure of 9 bar, a result that has been confirmed by other workers for both PDMS and MPF-50 membranes<sup>11,15</sup>. As water exhibits a high solubility parameter ( $\delta = 47.5 \text{ MPa}^{0.5}$ ) due to its polar nature it does not induce any appreciable swelling of the hydrophobic PDMS layer ( $\delta = 15.5 \text{ MPa}^{0.5}$ ) and the membrane remains in its dense state to prevent water permeation.

If PDMS is porous in the swollen state then the rejection of low-polarity, minimally interacting, solutes in good swelling solvents should be predominantly via a size-exclusion mechanism. To assess this possibility, the rejection behaviour of organic solute compounds with a range of molecular weights was determined in xylene ( $\delta = 18.2 \text{ MPa}^{0.5}$ ) at pressures of 6 bar (see Figure 3). From the data obtained the membrane appears to have a MWCO in the region of  $400 \text{ g mol}^{-1}$ . Increasing solute rejection with molecular weight has been reported by Gibbins *et al.* [13] for an MPF-50 membrane; here, solute molecular weights ranged from 170 to  $600 \text{ g mol}^{-1}$ . A size-exclusion mechanism is unlikely for dense membranes as solute transport is diffusive in nature. Although larger molecules can be expected to have very low rates of diffusion through dense membranes and thus high rejections, smaller molecules would not be expected to give zero rejections as observed in Figure 3. The latter could potentially occur through one of three scenarios:

- Solvent is transported via viscous flow and solute flux is diffusive. For this scenario to occur the solvent and solute fluxes would need to be identical.
- Solvent and solute fluxes both occur via a diffusive mechanism at identical rates.
- Solvent and solute are transported via a viscous flow mechanism at the same rate.

In the authors opinion, the most feasible explanation is the third scenario where the solvent swells the membrane sufficiently to induce a porous structure, and the zero rejections are due to the solvent and solute moving through the membrane structure 'as one' under viscous flow with no separation occurring. Zero rejections have previously been reported by van der Bruggen *et al.*<sup>15</sup>, who studied the rejection behaviour of a solute with a molecular weight of  $340 \text{ g mol}^{-1}$  in a range of solvents with an MPF-50 membrane. They found that solute rejection was zero in n-hexane, and suggest that contact with organic solvents increases the mobility of the polymeric chains in the membrane, allowing unhindered transport of solvent and solute. The data in Figure 3 strongly support the concept of a size-exclusion mechanism due to a porous structure, with the Solution-Diffusion mechanism being highly unlikely for the non-polar solvents and solutes studied here. Further evidence of a swelling induced porous structure is presented by Robinson *et al.*<sup>21</sup>.

Should a membrane become porous when swollen then the degree of swelling will affect the porosity and effective pore size of the membrane with a subsequent impact on separation performance. There are two methods of evaluating the separation characteristics with respect to the degree of swelling:

1. Measuring the rejection of a single solute compound in solvents of various swelling ability, i.e. different values of  $\delta$ . (Figure 4)

2. Measuring the rejection of a single solute compound in a single solvent using membranes with a varied degree of crosslinking. (Figure 5)

Figures 4 & 5 show that solute rejection is higher when the degree of swelling is low, that is when the membrane has a high degree of crosslinking or the solvent has a value of  $\delta$  which is significantly different from that of  $15.5 \text{ MPa}^{0.5}$  for PDMS. When the solvent has a value of  $\delta$  which is close to  $15.5 \text{ MPa}^{0.5}$ , or when the membrane has a low degree of crosslinking, the degree of swelling is high and the subsequent solute rejection is low. The results presented in Figures 4 & 5 are consistent with the proposed hypothesis, and suggest that for a particular solute, the degree of membrane swelling is a major factor governing solute rejection.

An estimation of the effective pore radius of the swollen membrane can be determined from a pore model first proposed by Ferry<sup>22</sup>. The model is able to predict pore radius based on the radius of a solute molecule and its corresponding rejection by assuming the membrane to comprise cylindrical pores. For 9,10 Diphenylanthracene, an equivalent solute radius of 0.71 nm was calculated from covalent radii and bond lengths within the molecule. For the 9,10 Diphenylanthracene rejections shown in Figure 4, the pore radius in a xylene solvent is calculated as 1.3 nm, compared with 1.6 nm in n-heptane. By way of comparison the steric hindrance pore model<sup>23</sup> gives pore radii of 1.2 nm in xylene and 1.7 nm in n-heptane. The pore radii predicted by the two models give an indication of the order of magnitude of the pore size in swollen PDMS membranes. For the 9,10 Diphenylanthracene solute, a comparison of the calculated molecule and membrane pore radii supports the relatively poor rejection noted.

## CONCLUSIONS

This study presents significant evidence to show that PDMS membranes exhibit the characteristics of a porous structure when swollen with a suitable solvent. Good agreement with the Hagen-Poiseuille model and the non-separation of binary solvent mixtures shows that viscous flow occurs through the membrane. The concept of viscous flow is also supported by the observation that the rejection mechanism for non-polar solutes is predominantly one of size exclusion. Poor-swelling solvents yield a lower flux and higher solute rejection than good-swelling solvents. It is postulated that swelling increases the effective pore size and porosity of the membrane and that the Hildebrand solubility parameter is a good indicator of swelling potential for solutes in non-polar solvents with a PDMS membrane as well as a good predictor of their subsequent flux/rejection behaviour.

## ACKNOWLEDGEMENTS

Shell Global Solutions (UK) are acknowledged for supplying project funding, technical hardware and isomeric solvents. EPSRC are also acknowledged for part-funding the project from which the presented work is taken. The PDMS membranes were kindly supplied by GKSS Forschungszentrum.

## REFERENCES

1. Scarpello J.T., Nair D., Freitas dos Santos L.M., White L.S. and Livingston A.G., 2002, The separation of homogeneous organometallic catalysts using solvent resistant nanofiltration, *J. Membrane Science*, **203**, 71-85.
2. Zwijnenberg H.J., Krosse A.M., Ebert K., Peinemann K-V. and Cuperus F.P., 1999, Acetone-stable nanofiltration membranes in deacidifying vegetable oil, *J. American Oil Chemists Society*, **76**, 83-87.

3. Paul D.R. and Ebra-Lima O.M., 1970, Pressure-induced diffusion of organic liquids through highly swollen polymer membranes, *J. Applied Polymer Science*, **14**, 2201-2224.
4. Flory P.J., 1953, *Principles of Polymer Chemistry*, Cornell University Press, Ithaca, NY.
5. Sun Y.-M. and Chen J., 1994, Sorption/desorption properties of ethanol, toluene and xylene in poly (dimethylsiloxane) membranes, *J. Applied Polymer Science*, **51**, 1797-1804.
6. Yoo J.S., Kim S.J. and J.S. Choi., 1999, Swelling equilibria of mixed solvent/poly (dimethylsiloxane) systems, *J. Chemical Engineering Data*, **44**, 16-22.
7. Bhanushali D., Kloos S., Kurth C. and Bhattacharyya D., 2001, Performance of solvent-resistant membranes for non-aqueous systems: Solvent permeation results and modelling, *J. Membrane Science*, **189**, 1-21.
8. Lonsdale H., Merten U. and Riley R., 1965, Transport of cellulose acetate osmotic membranes, *J. Applied Polymer Science*, **9**, 1341-1362.
9. Wijmans J.G. and Baker R.W., 1995, The solution-diffusion model: A review, *J. Membrane Science*, **107**, 1-21.
10. Sun Y.-M. and Chen J., 1994, Sorption/desorption properties of ethanol, toluene and xylene in poly(dimethylsiloxane) membranes, *J. Applied Polymer Science*, **51**, 1797-1804.
11. Favre E., Schaetzel P., Nguyen Q.T., Clement R. and Neel J., 1994, Sorption, diffusion and vapour permeation of various penetrants through dense poly (dimethylsiloxane) membranes: A transport analysis, *J. Membrane Science*, **92**, 169-184.
12. Barton A.F.M., 1983, *CRC Handbook of Solubility Parameters and Other Cohesion Parameters*, CRC Press, London.
13. Gibbins E., D'Antonio M., Nair D., White L.S., Freitas dos Santos L.M., Vankelecom I.F.J. and Livingston A.G., 2002, Observations on solvent flux and solute rejection across solvent resistant nanofiltration membranes, *Desalination*, **147**, 307-313.
14. Yang X.J., Livingston A.G. and Freitas dos Santos L., 2001, Experimental observations of nanofiltration with organic solvents, *J. Membrane Science*, **190**, 45-55.
15. van der Bruggen B., Geens J. and Vandecasteele C., 2002, Fluxes and rejections for nanofiltration with solvent stable polymeric membranes in water, ethanol and n-hexane, *Chemical Engineering Science*, **57**, 2511-2518.
16. Koops G.H., Yamada S. and Nakao S.-I., 2001, Separation of linear hydrocarbons and carboxylic acids from ethanol and hexane solutions by reverse osmosis, *J. Membrane Science*, **189**, 241-254.
17. GKSS Forschungszentrum. *Technical Datasheet*. October 2001.
18. Mulder M.H.V., 1991, *Basic Principles of Membrane Technology*, Kluwer Academic Publishers, Dordrecht.
19. Robinson J.P., Tarleton E.S., Millington C.R. and Nijmeijer A., 2004, Solvent flux through dense polymeric nanofiltration membranes, *J. Membrane Science*, **230**, 29-37.

20. Machado D.R., Hasson D. and Semiat R., 1999, Effect of solvent properties on permeate flow through nanofiltration membranes. Part 1: Investigation of parameters affecting solvent flux, *J. Membrane Science*, **163**, 93-102.
21. Robinson J.P., Tarleton E.S., Millington C.R. and Nijmeijer A., 2004, Evidence for swelling induced pore structure in dense PDMS nanofiltration membranes, *FILTRATION*, **4**(1), 50-56.
22. Ferry J.D., 1936, Statistical evaluation of sieve constants in ultrafiltration, *J. General Physiology*, **20**, 95-104.
23. van der Bruggen B., Schaep J., Wilms D. and Vandecasteele C., 2000, A comparison of models to describe the maximal retention of organic molecules in nanofiltration, *Separation Science Technology*, **35**(2), 169-182.

## FIGURES AND TABLES

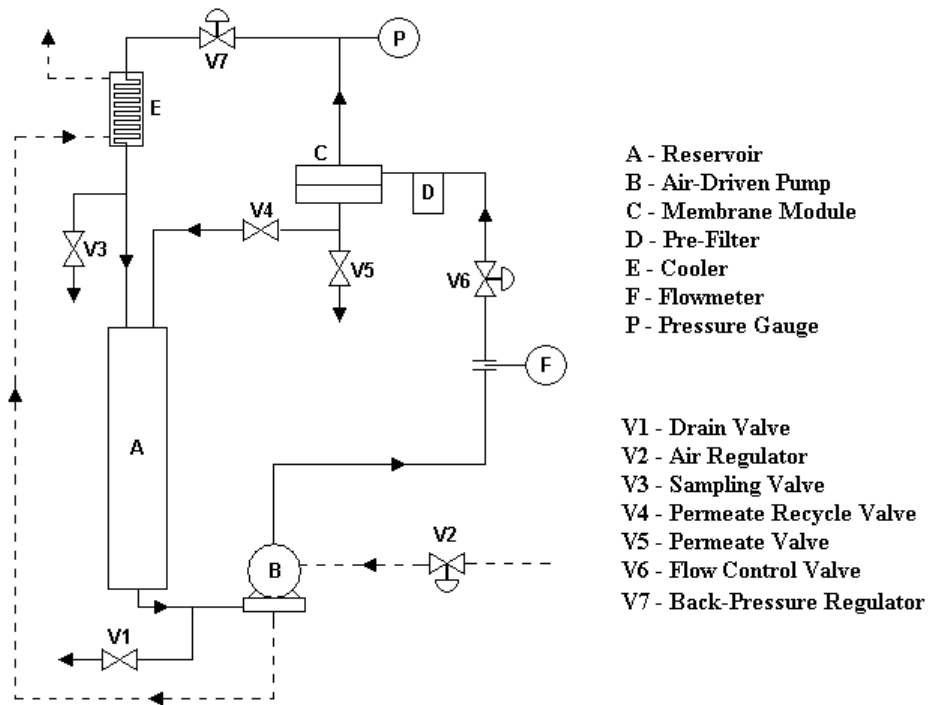

Figure 1: Schematic of air-driven crossflow filtration apparatus.

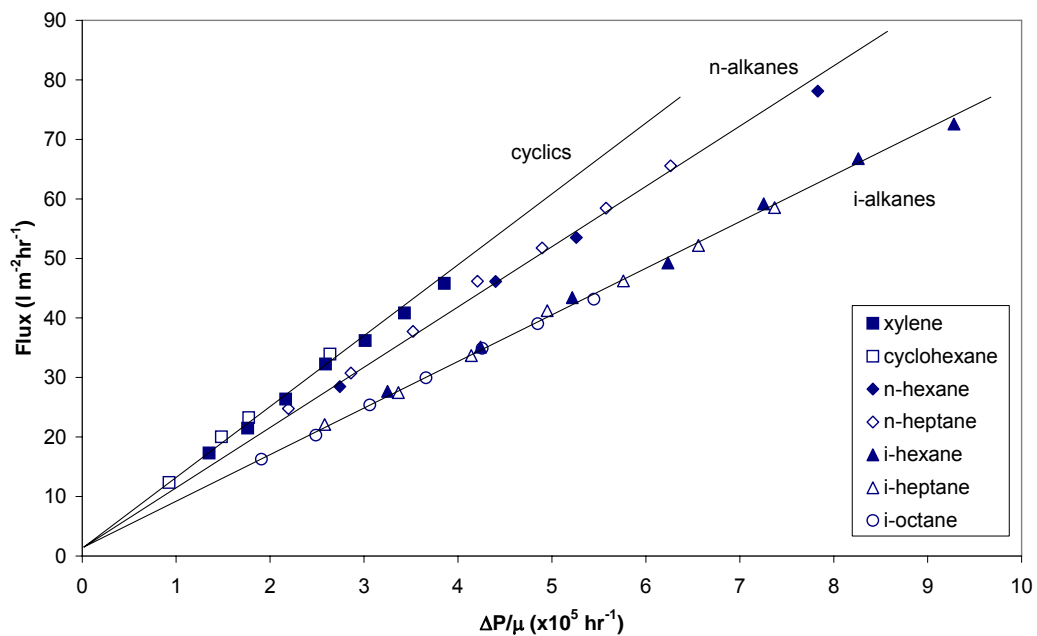

Figure 2: Solvent flux modelled with the Hagen-Poiseuille equation.

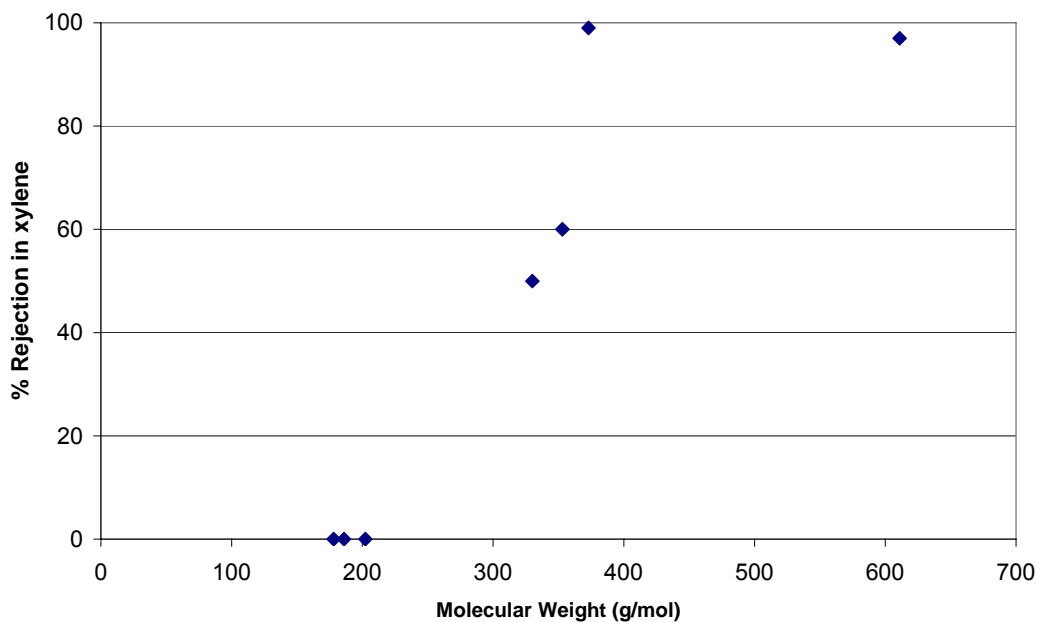

Figure 3: Solute rejection in xylene as a function of solute molecular weight.

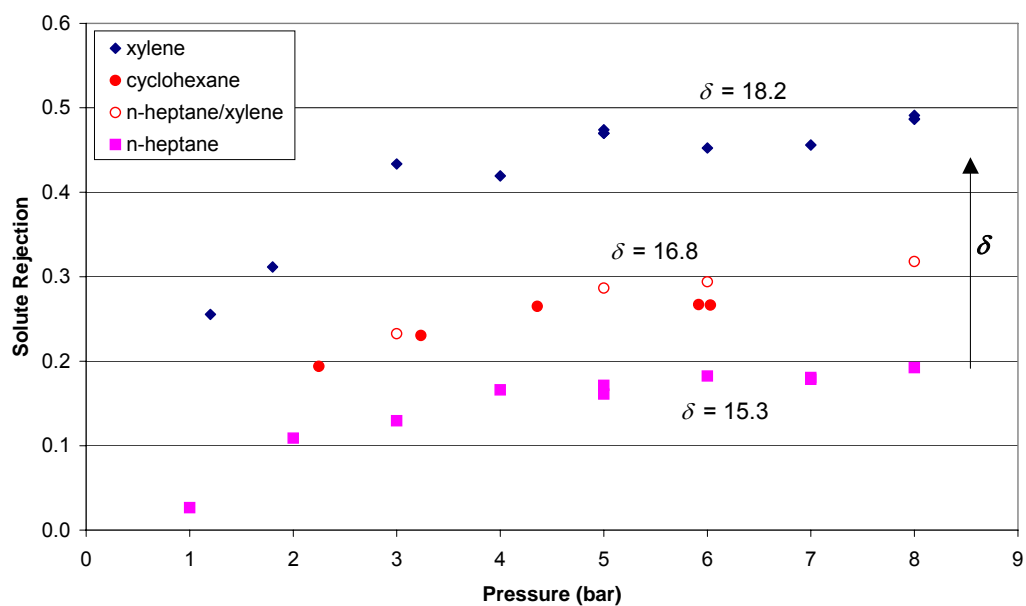

Figure 4: Effect of solvent-type ( $\delta$ ) on solute rejection. n-heptane/xylene mixture has identical value of  $\delta$  to cyclohexane.

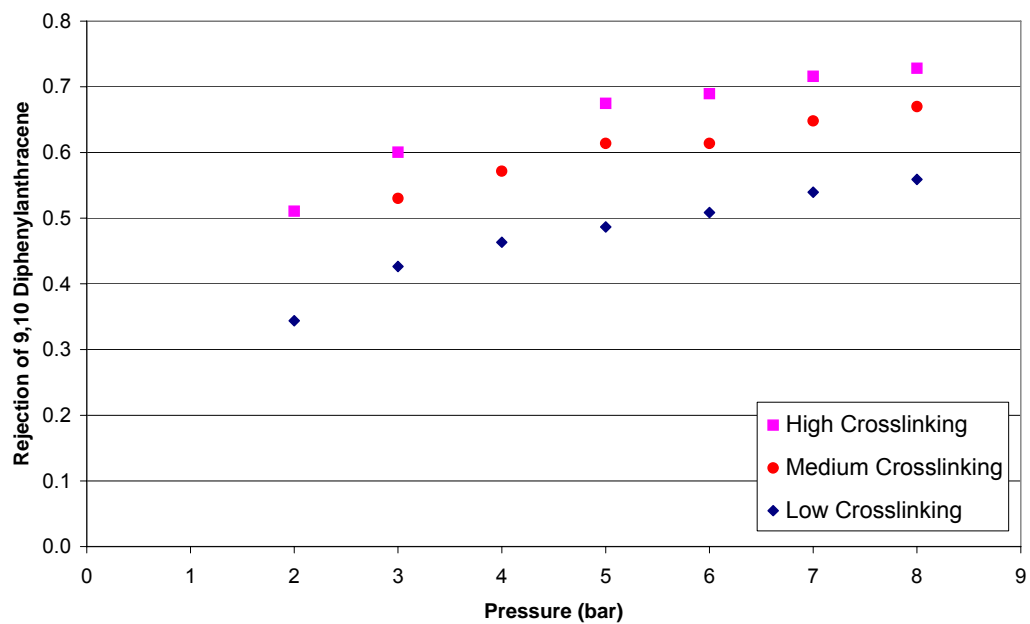

Figure 5: Effect of crosslinking on solute rejection in a xylene solvent.