

Loughborough University
Institutional Repository

*Crossflow micro- and
ultrafiltration augmented by
electric and ultrasonic force
fields*

This item was submitted to Loughborough University's Institutional Repository by the/an author.

Citation: TARLETON, E.S. and WAKEMAN, R.J., 1993. Crossflow micro- and ultrafiltration augmented by electric and ultrasonic force fields. World Filtration Congress 6, Nagoya, Japan.

Additional Information:

- This is a conference paper.

Metadata Record: <https://dspace.lboro.ac.uk/2134/5295>

Version: Not specified

Publisher: The Filtration Society / The Filtration Society Japan Association

Please cite the published version.

This item was submitted to Loughborough's Institutional Repository (<https://dspace.lboro.ac.uk/>) by the author and is made available under the following Creative Commons Licence conditions.

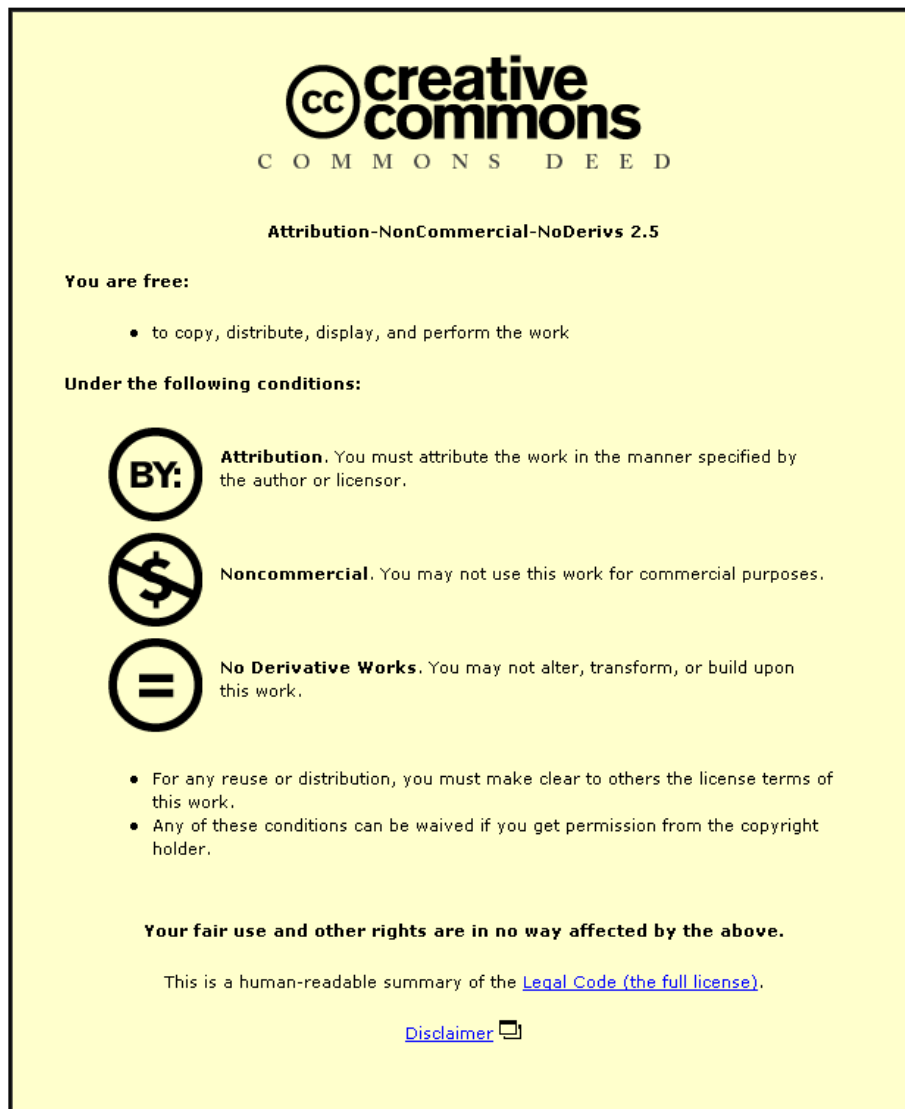

For the full text of this licence, please go to:
<http://creativecommons.org/licenses/by-nc-nd/2.5/>

CROSSFLOW MICRO- AND ULTRAFILTRATION AUGMENTED BY ELECTRIC AND ULTRASONIC FORCE FIELDS

E.S. Tarleton¹ (e.s.tarleton@lboro.ac.uk) and R.J. Wakeman²

¹Dept. of Chemical Engineering, Loughborough University, Loughborough LE11 3TU, UK.

²School of Engineering, Exeter University, Exeter EX4 4QF, UK.

ABSTRACT

An experimental study of field assisted crossflow filtration has shown that electric and ultrasonic fields, either in isolation or in combination, reduce membrane fouling. Particle liquid interfacial phenomena are used to advantage with the imposed fields to remove fouling layers and enhance flux rates. Synergistic effects were observed when the fields were applied simultaneously. Lower crossflow velocities can be utilised which implies that pumping costs, heat transfer in recirculation loops, and the degradation of shear sensitive streams can be reduced.

INTRODUCTION

Suspensions containing finer particulate and molecular material are difficult to process by filtration. The surface forces generated at the solid/liquid interface dictate dewatering rates and whilst membrane techniques such as crossflow ultra- and micro- filtration, where the bulk suspension flow is tangential to the filtering medium, are successfully used in many industries to process colloidal suspension the phenomenon of membrane fouling remains a recurring problem that prevents their more widespread use. The accumulation of macromolecular and finer particulate material at the septum during filtration can initiate rapid flux decline and result in unacceptably low separation rates. Although mechanical techniques such as backflushing can be used to (partially) clean fouled membranes the utilisation of particle-liquid interfacial phenomena through imposed force fields to augment filtration processes could provide an attractive solution to the fouling problem¹. This paper presents some results from an experimental study examining the influence of imposed electric and ultrasonic force fields on crossflow filtration.

EXPERIMENTAL PROCEDURES

The equipment used to assess the effectiveness of electric and ultrasonic fields is shown in Figure 1. The test rig consisted of a recirculation loop around which an aqueous (mineral) suspension of known and essentially constant composition was pumped continuously through a crossflow microfilter at constant crossflow velocity, trans-membrane pressure and temperature. The purpose built microfilter was constructed from plastics and stainless steel (as was the rest of the flow circuit and ancillaries) and comprised a supported 38 cm² membrane positioned to form one side of a rectangular flow section. The design allowed for the inclusion of mesh electrodes either side of the planar membrane and ultrasound sources in contact with the suspension on the retentate side of the membrane. Several interchangeable filter bodies enabled the distance between the ultrasound source and the membrane to be varied from 15 to 100 mm whilst maintaining a fixed 3 cm gap between the electrodes used to generate the electric field. The ultrasound transducers capable of generating frequencies of 23 kHz and 40 kHz gave nominal power outputs of 3 W cm⁻² and were mounted such that the generated ultrasound waves travelled through the feed suspension to impinge on any surface foulant or deposit which may have accumulated on the membrane. The electric field was applied through the electrodes from a constant voltage DC power supply capable of delivering up to 10 A at 400 V.

EXPERIMENTAL RESULTS

Cite paper as: Tarleton E.S. and Wakeman R.J., 1993, Crossflow micro- and ultrafiltration augmented by electric and ultrasonic force fields, *Proc. 6th World Filtration Congress*, pp.926-929, Japanese Society Chemical Engineers, Nagoya.

The experimental programme identified the principal process and suspension characteristics which most affected the field assisted microfiltration of aqueous feed streams. Parameters such as applied field strengths, acoustic frequency, suspension concentration, liquid viscosity, particle size and particle surface charge all influenced membrane fouling to an extent dependent on their relative magnitudes¹⁻³. Both individual electric and ultrasonic fields reduced membrane fouling over a range of process conditions; this being principally induced by electrokinetic effects, such as electrophoresis and electroosmosis, and cavitation respectively.

The extent of flux improvement when using a DC electric field is typically an order of magnitude and dependent on particle size, the magnitude of the imposed field gradient and the surface charge characteristics of the dispersed phase. The latter is closely associated with the environment near to and at the particle surfaces and can be tailored such that flux levels are significantly improved. Greater flux enhancements are possible in electrofiltration for finer particles carrying higher surface charges (higher ζ -potentials) when using steeper field gradients⁴. Investigations have shown that crossflow velocities of 0.1 m s^{-1} rather than the more normal 2 to 8 m s^{-1} can be used to advantage⁵. The potential advantages are reduce pumping costs, less heat input into the process stream, and the improved possibilities of processing shear sensitive streams, albeit at the expense of the energy input required to generate the electric field.

Figure 2 shows how an ultrasonic field, in the absence of an electric field, can reduce particulate fouling and hence flux decline in microfiltration. By increasing the intensity of the ultrasound field (expressed in this work as an ultrasonic power density gradient, $\text{W cm}^{-2} \text{ cm}^{-1}$) filtrate flux improvements up to an order of magnitude could be achieved. The gradient was varied by using an ultrasonic source with a fixed power output and changing its separation distance from the membrane surface. Whilst the flux improvements shown in Figure 2 are fairly typical of what can be achieved (with crossflow velocities near to 0.1 m s^{-1}), higher ultrasonic frequencies, suspension concentrations, suspension viscosities and the presence of larger size particles in the feed stream reduce the effectiveness of the applied ultrasound.

Figure 3 shows the typical contributions of each field to a combined field filtration. Both electric and ultrasonic fields were seen to reduce fouling when applied individually, but the extent of improvement by the ultrasonic field could be minimal when the feed stream concentration was higher. The improvement by the electric field was usually greater than that due to the ultrasonic field¹, particularly when the particles were well dispersed. When the electric and ultrasound fields were applied simultaneously a synergistic interaction occurred whereby flux levels were above those which could be expected from the simple addition of the flux improvements due to the individual fields. The synergy seemed greater with the more problematic suspensions and in particular at higher feed concentrations (the tests in Figure 3 were performed at a concentration of 10.1% w/w).

The experimental data shown illustrate the large flux increases which are achievable when electric and/or ultrasonic fields are used to aid microfiltration. However, to increase the filtration rate is not necessarily a sufficient criterion by which to assess filter performance. The energy consumed in achieving that rate can be equally as important.

Table 1 gives a breakdown of the power consumptions for two groups of tests. The data indicate the contributions to the power consumed by the filter system for the pump used to provide the crossflow, the constant voltage (50 V cm^{-1}) D.C. electric field and the 23 kHz ($1.7 \text{ W cm}^{-2} \text{ cm}^{-1}$) ultrasonic field. The power input figures are quoted per unit membrane area whilst the energy consumed is expressed per unit volume of filtrate. Experiments performed with no imposed force fields employed a crossflow of 2.3 m s^{-1} (for comparison purposes) whereas all the assisted filtrations used the lower crossflow of 0.1 m s^{-1} . While the data highlight that actual power inputs with imposed fields were in all cases higher than the corresponding tests with no fields, the energy required to produce a unit volume of filtrate could be decreased significantly for both anatase and

china clay suspensions. Moreover, the time taken to extract a unit volume of filtrate from each suspension was reduced with the combined fields by x18 and x10 respectively.

In the light of supplementary work carried out alongside this project it is considered that the energy consumed by the electric field could be reduced by 25 to 30%, and that consumed by the ultrasonic field by factors somewhat larger. This would reduce power input levels to between one-half and two-thirds of those shown on Table 1 whilst retaining the filtration rates shown.

CONCLUDING REMARKS

Whilst some of the observations in the experiments are difficult to interpret theoretically due to the complexity of the interactions the effects generated during assisted filtrations are often substantial and could be observed with a range of suspensions exhibiting different properties. The ability to prevent membrane fouling using imposed force fields offers the potential advantage of improved separation rates at reduced pumping costs. Preliminary comparisons of the energy requirements for conventional and field assisted microfiltrations indicate that lower overall power consumptions can be achieved with the latter. Moreover, the reduced pumping requirement has practical implications concerning the processing of shear sensitive feed streams. Such streams should undergo less degradation by the recirculation pump and require reduced cooling in batch systems.

ACKNOWLEDGEMENTS

The authors wish to acknowledge receipts of grants from the Specially Promoted Programme in Particulate Technology of the Science and Engineering Research Council in support of this work, and of additional support from the company members of the Separation Processes Centre at Exeter University.

REFERENCES

1. R.J. Wakeman and E.S. Tarleton, 1991, *Chem. Eng. Res. Des.*, **69(A)**, 386-397.
2. R.J. Wakeman and E.S. Tarleton, 1986, *Chem. Eng. Sci.*, **42**, 829-842.
3. E.S. Tarleton and R.J. Wakeman, 1992, *Filtration and Separation*, **29(5)**, 425-432.
4. E.S. Tarleton, 1986, *PhD Thesis*, University of Exeter.

TABLES AND FIGURES

Filtrate flux ($\text{m}^3 \text{m}^{-2} \text{h}^{-1}$)	Crossflow velocity (m s^{-1})	Field gradients (V mm^{-1}) ($\text{W cm}^{-2} \text{cm}^{-1}$)	Power/energy consumption*			
					Totals	
			Applied field(s) (kW m^{-2})	Pump (kW m^{-2})	(kW m^{-2})	((kW h) m^{-3})
0.5 ^a	2.3	0	0	19.6	19.6	39.3
0.4 ^a	0.1	0	0	0.02	0.02	0.05
0.12 ^b	0.1	0	0	0.02	0.02	0.17
0.71 ^b	0.1	5	93.9	0.02	93.92	132.3
4.41 ^b	0.1	5/1.7	124.7+24.9	0.02	149.62	33.9
0.2 ^c	0.1	0	0	0.02	0.02	0.1
1.5 ^c	0.1	5	9.1	0.02	9.12	6.08
2.3 ^c	0.1	5/1.7	13.0-24.9	0.02	37.92	16.5

*Power per unit area of filter; energy per unit volume of filtrate; ^a0.33% v/v anatase suspension at pH 9.1; ^b2.8% v/v anatase suspension at pH 8.1; ^c1.4% v/v china clay suspension at pH 6.2

Table 1: Power consumptions during normal and enhanced crossflow microfiltration.

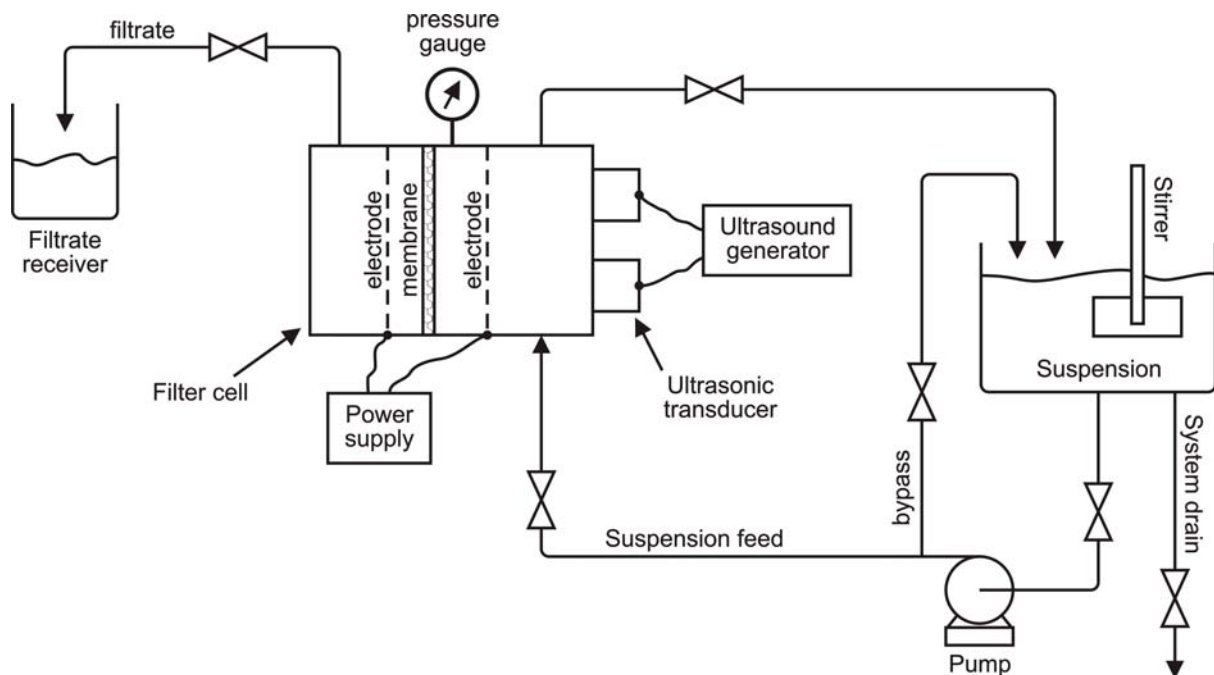

Figure 1: Schematic diagram of the microfiltration cell and flow circuit.

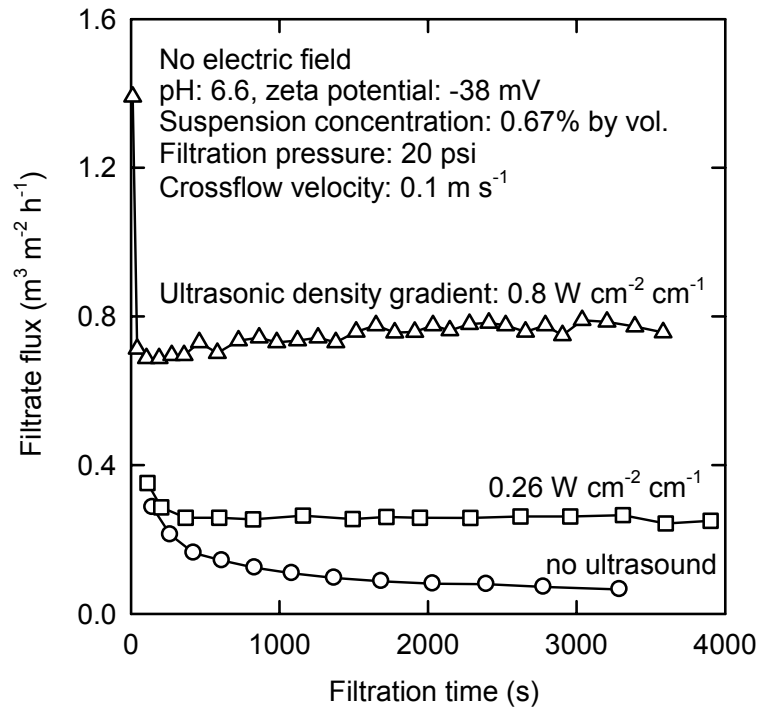

Figure 2: Effect of ultrasonic field gradient on flux decline for anatase suspensions.

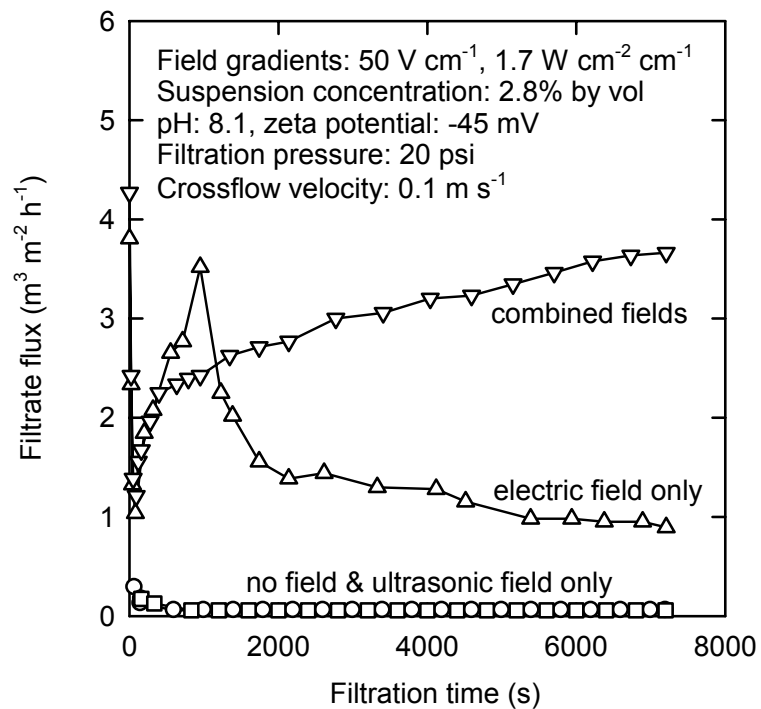

Figure 3: Synergy between electric and ultrasonic fields for anatase suspensions.