

Loughborough University  
Institutional Repository

---

*A philosophy for the  
selection, scale-up and  
process simulation of filters*

This item was submitted to Loughborough University's Institutional Repository by the/an author.

**Citation:** TARLETON, E.S. and WAKEMAN, R.J., 2000. A philosophy for the selection, scale-up and process simulation of filters. World Filtration Congress 8, Brighton, UK.

**Additional Information:**

- This is a conference paper.

**Metadata Record:** <https://dspace.lboro.ac.uk/2134/5294>

**Version:** Not specified

**Publisher:** The Filtration Society

Please cite the published version.

This item was submitted to Loughborough's Institutional Repository (<https://dspace.lboro.ac.uk/>) by the author and is made available under the following Creative Commons Licence conditions.

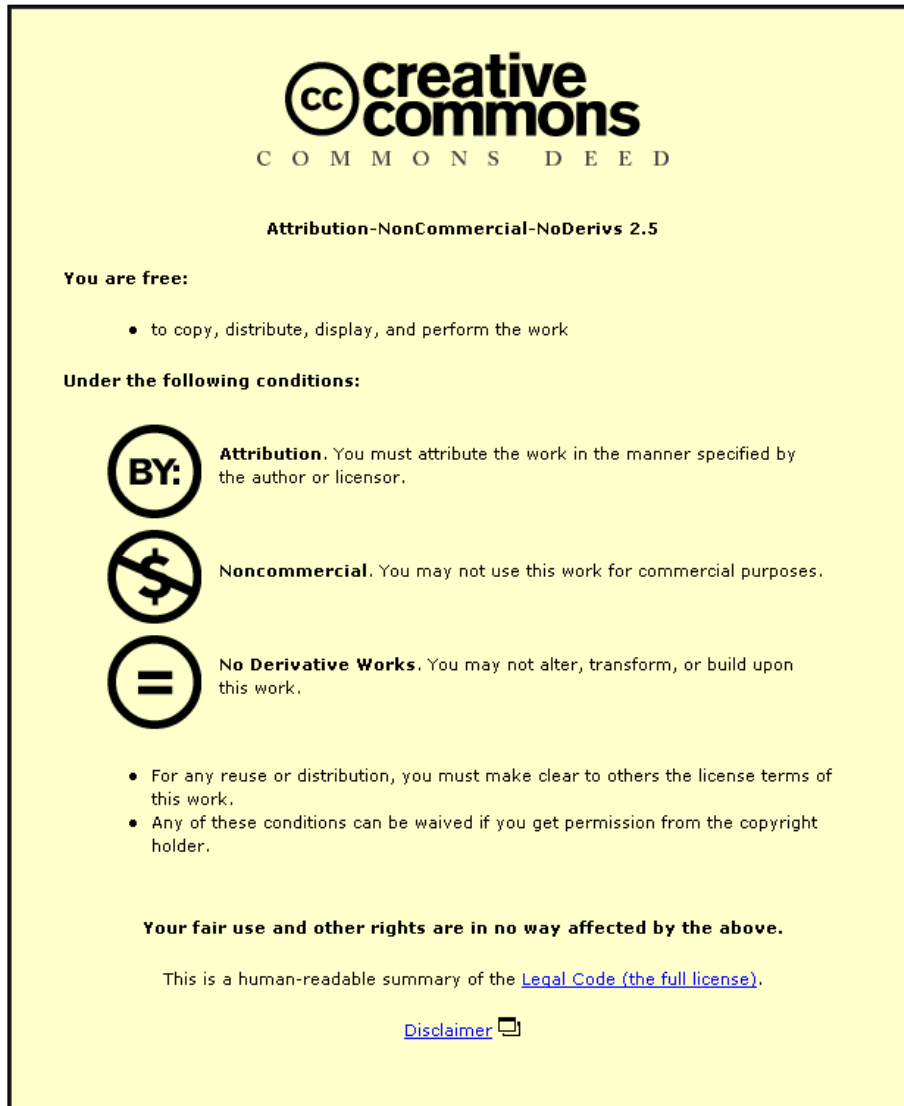

**CC creative commons**  
COMMONS DEED

**Attribution-NonCommercial-NoDerivs 2.5**

**You are free:**

- to copy, distribute, display, and perform the work

**Under the following conditions:**

**BY:** **Attribution.** You must attribute the work in the manner specified by the author or licensor.

**Noncommercial.** You may not use this work for commercial purposes.

**No Derivative Works.** You may not alter, transform, or build upon this work.

- For any reuse or distribution, you must make clear to others the license terms of this work.
- Any of these conditions can be waived if you get permission from the copyright holder.

**Your fair use and other rights are in no way affected by the above.**

This is a human-readable summary of the [Legal Code \(the full license\)](#).

[Disclaimer](#) 

For the full text of this licence, please go to:  
<http://creativecommons.org/licenses/by-nc-nd/2.5/>

## A PHILOSOPHY FOR THE SELECTION, SCALE-UP AND PROCESS SIMULATION OF FILTERS

E.S. Tarleton ([e.s.tarleton@lboro.ac.uk](mailto:e.s.tarleton@lboro.ac.uk)) and R.J. Wakeman

Department of Chemical Engineering, Loughborough University, Loughborough, Leics., LE11 3TU, UK.

### ABSTRACT

This paper details some generic aspects of a co-ordinated approach to the selection, scale-up and process simulation of filtration and separation equipment. An interactive computer software package capable of identifying a likely separation device is outlined briefly. Choosing the example of cake filters, the beneficial use of computer software and automated data acquisition in laboratory apparatus is illustrated and it is shown how the typical experimental data generated can be analysed in a consistent manner by computer software to generate scale-up data. The paper also indicates how this information can be used within a family of dedicated process modelling software packages to simulate detailed filter cycle operations on batch and continuous cake filters.

### KEYWORDS

Selection; Scale-up; Process simulation; Computer software.

### INTRODUCTION

For the selection, scale-up, design or optimisation of solid/liquid separation equipment it is unusual to use fundamental theoretical relationships solely. Equipment is rarely specified without recourse to laboratory and pilot scale tests and the data produced can lead to erroneous scale-up and separator installation unless care and consistency are observed. Progressive developments by the authors<sup>1-7</sup> have facilitated an integrated theoretical and experimental approach to this subject area. The overall philosophy with reference to filter selection, software assisted data analysis and process modelling is described here.

### EQUIPMENT SELECTION USING $p^C$ -SELECT

Of the available procedures for the selection of solid/liquid separation, those involving a blend of rule-based protocols and user interaction have proved the most successful. Since the early 1990's the commercially available software  $p^C$ -SELECT<sup>1,7</sup> has facilitated both a consistent procedure for the calculation of basic filtration and sedimentation parameters (such as cake formation and settling rates) and an interactive methodology for producing ranked lists of equipment potentially suited to a given duty. The software utilises databanks of ranked equipment characteristics and can be used in a variety of ways ranging from a single usage, through repeated 'what if' assessments, to sophisticated analyses of multiple feed batch plants. Taking the latter as an illustrative example, and assuming a feed rate equivalent to  $15 \text{ m}^3 \text{ h}^{-1}$ , Table 1 shows some basic sedimentation and filtration test results for five different feeds and a requirement for either solids deliquoring or washing.

By repeated use of the automated selection procedures in  $p^C$ -SELECT, the data shown in Table 2 can be produced where the relative performance index for a deliquoring or washing operation can take a maximum value of 9. Inspection of Table 2 indicates that only the vacuum horizontal belt, tilting pan or table filter or the pressure Nutsche filter are best suited to processing four of the five feeds. However, only the former three are capable of processing all five in an effective manner.

Should only the un-flocculated feeds need to be processed, then it is likely that the vacuum filters will give slightly superior overall performance. Through other performance indices, p<sup>C</sup>-SELECT will also indicate that the pressure Nutsche filter is likely to give a better clarity liquid product, although any improvement may ultimately be marginal and a final selection may depend on other over-riding factors<sup>1</sup>.

## DATA GENERATION, ANALYSIS AND SCALE-UP

In order to acquire experimental data for initial equipment selection it is likely that relatively simple experimental apparatus, such as a 100 cm<sup>2</sup>, manually operated leaf filter, is sufficient. However, for accuracy in scale-up it is likely that more sophisticated computer controlled apparatus is required. Several laboratory scale apparatus capable of automated data acquisition during the filtration, washing, deliquoring and consolidation phases of a filter cycle have been developed by the authors<sup>1,2</sup> to facilitate sequential experiments over a range of pressure/flow regimes with a minimum of operator interference (see Figure 1 for an example).

The data generated allow the scale-up parameters needed for process modelling to be calculated and generally provide for accurate theoretical prediction due to the controlled manner of acquisition (e.g. Figure 2). Their consistent analysis can be aided by computer software<sup>5</sup>. Using an expression test as an example, Figures 3 and 4 show sample displays of how the change from filtration to cake consolidation can be identified by the software user with the aid of interactive cursors and computer assisted suggestions for transition points. With the additional knowledge of basic experimental conditions the software package allows for the analysis of a single experiment to give eighteen characterising parameters including cake resistance, porosity and consolidation index. By repeated software analysis of a sequence of experiments over ranges of pressure the automatic calculation of scale-up constants for both filtration and consolidation processes is possible. Adding the scale-up parameters for washing and deliquoring phases<sup>1</sup> provides the information for detailed process simulations.

## PROCESS FILTER SIMULATION

With a knowledge of the type of separator and scale-up constants for the different phases of a filter cycle, it is possible to employ process simulations in order to assess likely equipment performance<sup>1,6</sup>. Although full details of such simulations are beyond the scope of this paper, Figure 5 illustrates in simplified form the basic steps (based on computer software developed by the authors). To be most effective a simulation must include well chosen calculation procedures and algorithms, be able to ensure input data correctness as far as this is possible and utilise interactive graphics facilities, whilst overcoming the sometimes natural reluctance to use computers.

In generic terms, at the start of a simulation the filter type and the required cycle phases are interactively defined by a user along with data storage file names. The information relevant to each phase is also interactively defined and the magnitude of the numbers entered is checked by the software as much as this is possible. The cycle calculations are then performed for the pre-defined sequential phases to give the necessary data which describe filter operation. These results are displayed either graphically or in tabular form on the computer screen and printed and/or saved to computer disk as appropriate (an example display from a diaphragm press filter cycle is shown in Figure 6). A typical simulation takes a few minutes including input of data such as solid/liquid properties, scale-up constants and the required process and product conditions.

## CONCLUSIONS

The philosophy outlined in this paper points a way to an integrated package for filter selection, design and scale-up. To date the authors have developed several automated laboratory scale apparatus and computer software capable of equipment selection, detailed data analysis for scale-up and process simulations for several batch pressure and continuous vacuum filters<sup>1</sup>. The models used for calculations and simulations are based on fundamental theories and proven laboratory and process scale practical results. Use of the authors philosophy could prevent the implementation of equipment whose actual performance subsequently falls below anticipated operating demands, and certainly enables the user engineer to perform independent checks on equipment manufacturers design and performance claims. It is not the detailed results shown in this paper which are necessarily important, but it is the underlying methodology which has potentially widespread implications.

## REFERENCES

1. Wakeman R.J. and Tarleton E.S., 1999. *Filtration: Equipment Selection, Modelling and Process Simulation*, Elsevier Advanced Technology, Oxford.
2. Tarleton E.S. and Hancock D.L., 1997, *Trans IChemE*, **75(A)**, 298.
3. Wakeman R.J. and Tarleton E.S., 1994, *Min. Engng*, **7(11)**, 1411.
4. Wakeman R.J. and Tarleton E.S., 1990, *Filt. and Sep.*, **27(6)**, 412.
5. Tarleton E.S. and Wakeman R.J., 1999, *Filt. and Sep.*, **36(8)**, 57.
6. Wakeman R.J. and Tarleton E.S., 1999, *Filt. and Sep.*, **36(8)**, 24.
7. Tarleton E.S. and Wakeman R.J., 1991, p<sup>c</sup>-SELECT software, STA, Loughborough.

## FIGURES AND TABLES

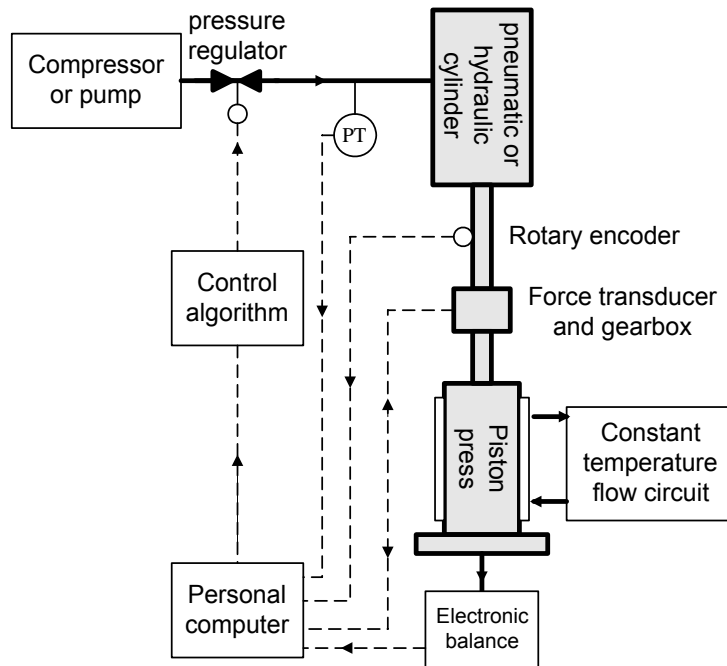

Figure 1: Automated expression apparatus.

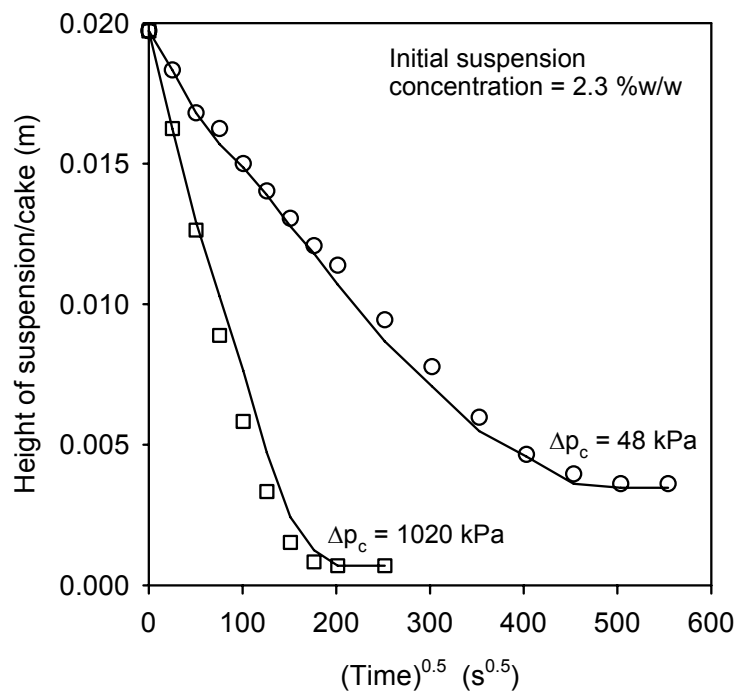

Figure 2: Typical comparison of experiment and expression theory<sup>1</sup>.

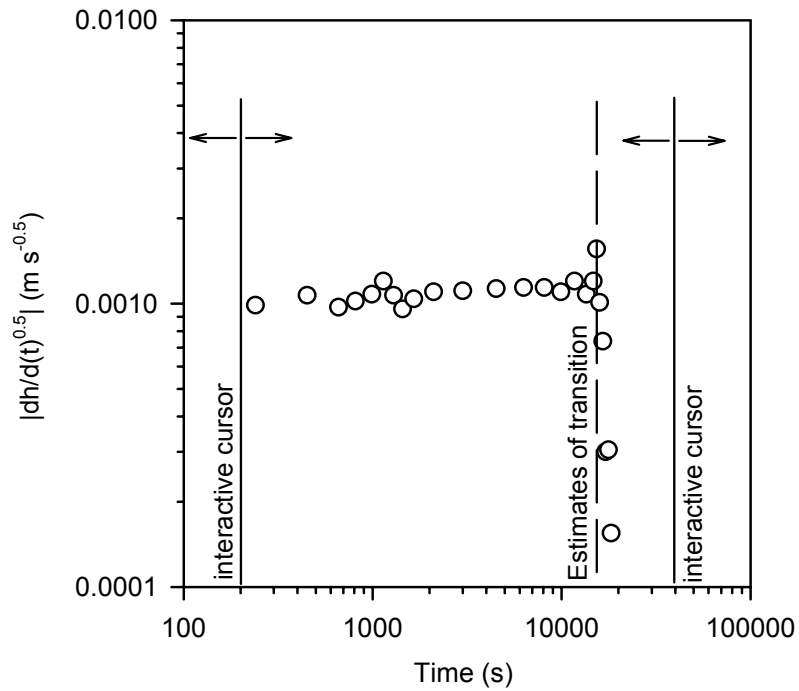

Figure 3: Estimating the filtration to cake consolidation transition via software<sup>5</sup>.

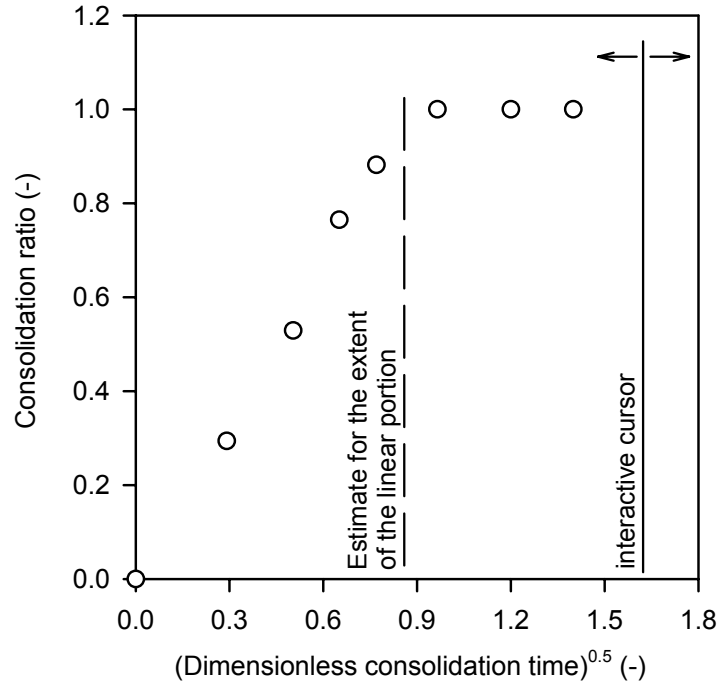

Figure 4: Identifying the initial linear portion of a cake consolidation.

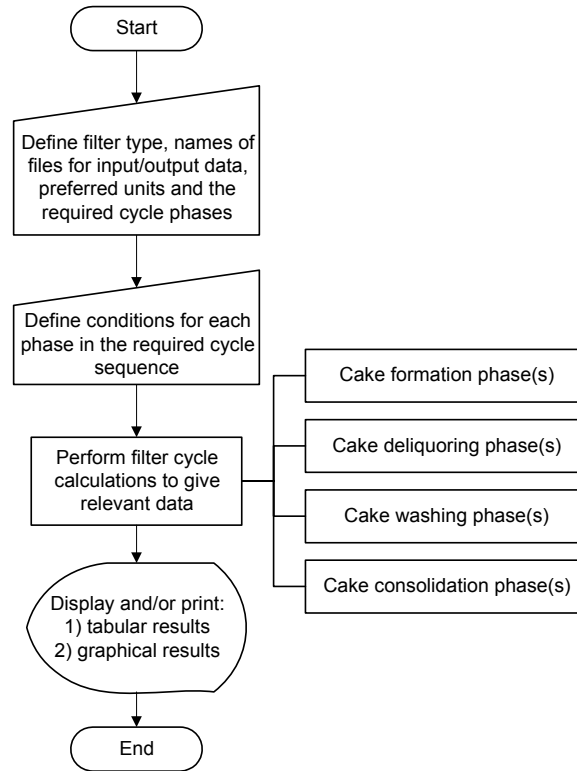

Figure 5: Basic flowsheet for modular filter simulations.

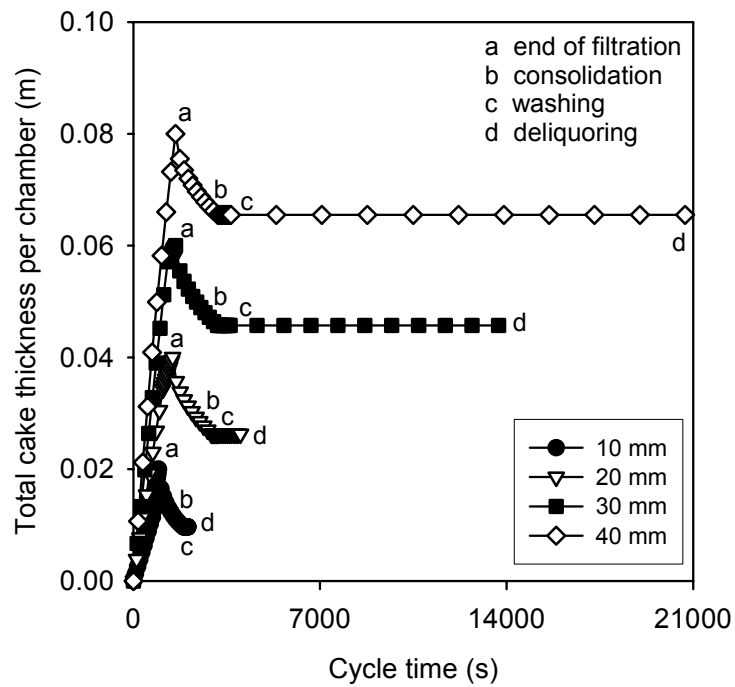

Figure 6: Sample results from a diaphragm press simulation.

Selection parameter	# 1	# 2	# 3	# 4	# 5*
Primary objective	D	D	D	D or W	D or W
Settling rate (cm s <sup>-1</sup> )	< 0.1	< 0.1	< 0.1	0.1-5	> 5
Clarity of supernatant	poor	poor	good	good	good
Sediment concentration (% v/v)	< 2	> 20	> 20	2-20	2-20
Filter cake growth rate (cm min <sup>-1</sup> )	< 0.02	< 0.02	0.02-1	0.02-1	> 1

D ≡ deliquored, W ≡ washed, \* # 5 is flocculated from # 4

Table 1: Objective and settling/filtration characteristics for five batch feeds.

Equipment type	# 1	# 2	# 3	# 4	# 5
	D	D	D	D W	D W
Horizontal belt or rotary tilting pan filter	7	7	7	7 9	7 9
Rotary table filter	7	7	7	7 8	7 8
Filter press	6	6	-	- -	- -
Single leaf (Nutsche) pressure filter	6	6	6	6 8	- -
Multi- tubular element pressure filter	5	-	-	- -	- -
Multi- vertical element leaf pressure filter	5	-	-	- -	- -
Multi- horizontal element leaf pressure filter	-	-	-	- 8	- -
Diaphragm filter press	-	8	8	8 8	- -
Single leaf (Nutsche) vacuum filter	-	6	6	6 8	- -
Tube press	-	8*	8*	8* 4*	- -
Basket (pendulum) centrifuge	-	9	9	9 6	9 6
Basket (peeler) centrifuge	-	-	9	9 6	9 6
Circular basin thickener	-	-	-	- 2	- 2
Screen (sieve bend) classifier	-	-	-	- 4*	- 4*
Gravity Nutsche filter	-	-	-	4* 7*	4* 7*

\* marginally acceptable on selection criteria, '-' ≡ unsuitable equipment

Table 2: Equipment rating criteria as identified by p<sup>C</sup>-SELECT.